

YD Circular Connector

Coupling: Thread
Terminal: Solder



Connectors are applied to the rail transport, electric power equipment, engineering machinery, thermoplastic machinery, industrial automation, robot, high and low voltage electric control cabinets electrical connection and signal transmission.



ISO9001

ISO14001

ISO45001





Index

Profile	2
Assemble Parts, Crimp, Insertion & Extraction	3
Technical Data	4
Part Number Explanation	5-18
Receptacle	5-7
Receptacle① (Panel Mounted, No Protective Enclosure)	5
Receptacle② (Protective Enclosure, Clamp/Gland)	6
Receptacle-Protective Enclosure, Code for Outlet	7
Plug	8-9
Plug-Shell Style, Code for Outlet	9
Coupling Map of Receptacle (Panel Mounted) & Plug	10
Contacts Arrangement	11-18
Size of Receptacle & Plug	19-21
Receptacle① (Panel Mounted, No Protective Enclosure) , Receptacle Mounting & Mounting Hole	19
Receptacle② (Protective Enclosure, Clamp/Gland)	20
Plug	21
Accessories	22



TUV SUD



TVV



ISO9001

ISO14001

ISO45001



华伦连接器
HuaLun Connector

Profile

Design standard: IEC61984.

Technical Data:

- ① Coupling: thread ② Terminal: solder ③ Equipped with lengthened grounding pin in first mate/last break structure.
- ◆ Shell Spec: 20, 28, 32, 40, 48, 55.
- ◆ No. of Contacts: 2-86pins, more than 100 spec.
- ◆ Plug: ① straight ② 90° angled
- ◆ Four types of outlets.
- ◆ Our products conform to German TUV, America UL, European CE and passed the RoHS test.
- ◆ Degree of protection: IP65
- ◆ The products are used for electrical circuit connection and signal transmission of various mechanical equipment

Hualun connectors are appointed by Chinese rail transport, engineering machinery, power electric power, thermoplastic machinery, industrial automation, and robot manufacturing enterprises. as a perennial supporting product.

CERTIFICATE



High-tech Enterprise Certificate



Foreign Invested Advanced



Enterprise Credit Rating AAA



Software Copyright



ISO9001, ISO14001, ISO45001

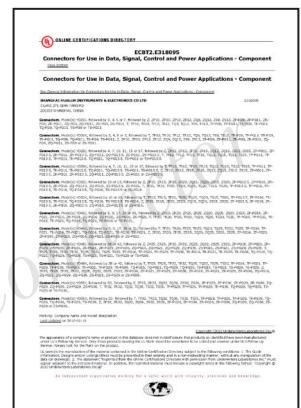

UL for YD series

Live parts should not be disassembled without authorization!!!



TIPS

- 1 After the wire is welded, be sure to seal the heat shrinkable sleeve at the welding site



- 2 Especially Recommended Mounting Plate

Technical advantages:
Convenient and Fast! Firm!

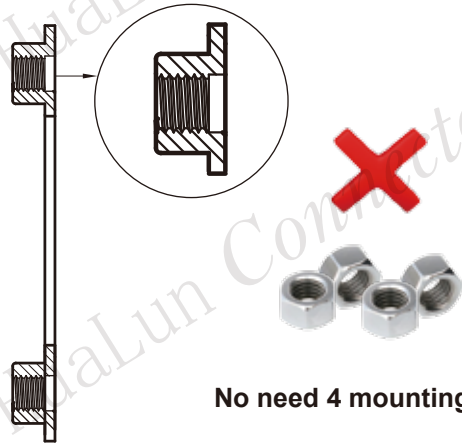
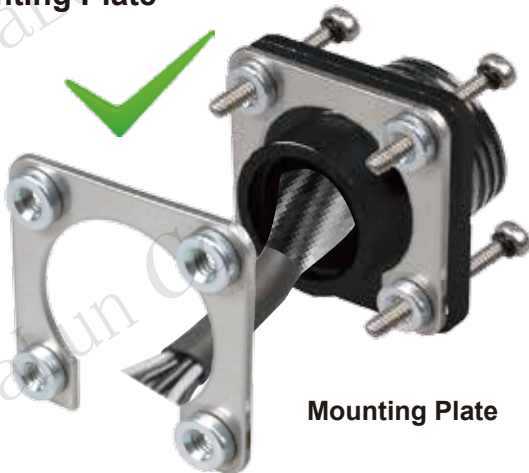

Technical Data

● Environmental, Mechanical Features

Operating Temperature	Upper limit+125°C *1 Lower limit-55°C *2
Relative Humidity	93%~95% at 40°C±2°C
Salty Spray Corrosion	≥96h
Protection Degree	IP65/IP67 (when mated,wired and mounted according to DS)
Shock Vibration	Class 1B (GB/T21563-2018)
Mechanical Life	≥500

Note:*1 The upper limit temperature is the maximum internal hot spot temperature that occurs in either combination of electrical load and environmental conditions.

*2 The minimum allowable operating temperature value of the connector according to the defined climate category (upper and lower limit temperatures and damp heat test time, as defined in the climate category in GB/T2421.1)

● Electric Features

Degree of Pollution	2/3	Overtoltage Category	II / III
Insulation Resistance	Normal: ≥5000MΩ, (Dynamic values see tableA)		
Contact Diameter (mm)	φ 1.5	φ 2.5	
Rated Current	10A	25A	
Rated Voltage	<div style="border: 1px solid red; padding: 2px; display: inline-block;">See Contacts Arrangement Page11~18</div>		
Rated Impulse Voltage			
Wire Gauge			
Contact Resistance	Remark: For High Altitude Low Pressure Environment Refer to GB/T4797.2-2005		

TableA The limit value of insulation resistance varies with temperature

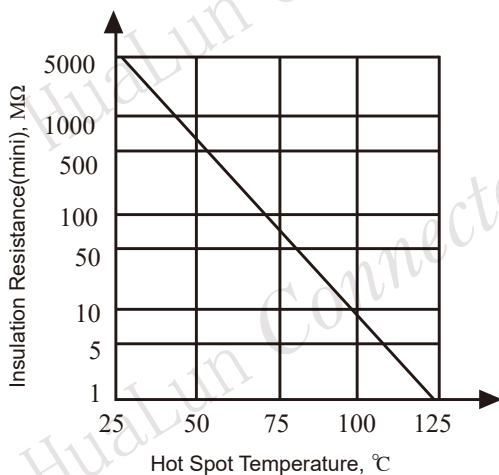

Current-Carrying Capacity Curve (IEC/EN 60512-5)

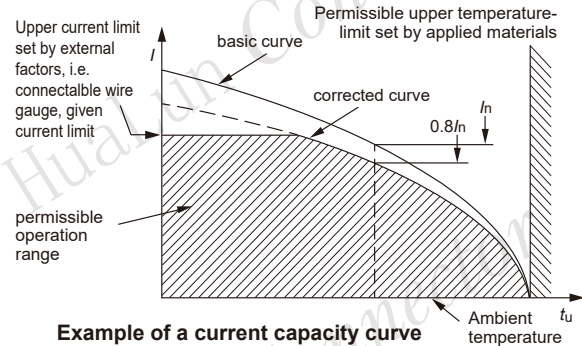

Example of a current capacity curve

- ◆ The rated current is the continuous, not interrupted current a connector can take when simultaneous power on all contacts is given, without exceeding the maximum temperature.
- ◆ For the rated current of multi-pin connectors, the derating should be shown according to the "derating curve" graph. For the derating rate, please refer to the table below

Contact current De-rating

Qty of contacts	1~10	11~20	21~30	31~50	51~80
Drop rate%	0	10	20	30	40

● Material: RoHS

Shell	Aluminum Alloy (Electrophoresis, Black)
Contact	Copper Alloys (Silver) Gold plating, customize
Insert	Plastic UL Certificate
	Flame Resistance UL94V-0

Dielectric Strength Test Voltage

Rated Impulse Voltage (U _{imp}) kV	Test voltage-Pulse Withstand Voltage kV(1.2/50μs)		Withstand Voltage Test (r.m.s) kV(50/60Hz)
	Altitude 2000m	Sea Level	
0.5	0.5	0.55	0.37
0.8	0.8	0.91	0.50
1.5	1.5	1.75	0.84
2.5	2.5	2.95	1.39
4	4	4.8	2.21

Testing Condition

Temperature:15°C~35°C	Relative Humidity:20%~80%	Atmospheric Pressure:73KPa~106KPa
-----------------------	---------------------------	-----------------------------------

Part Number

(Explanation)

Receptacle ① (Panel Mounted)
(No Protective Enclosure)

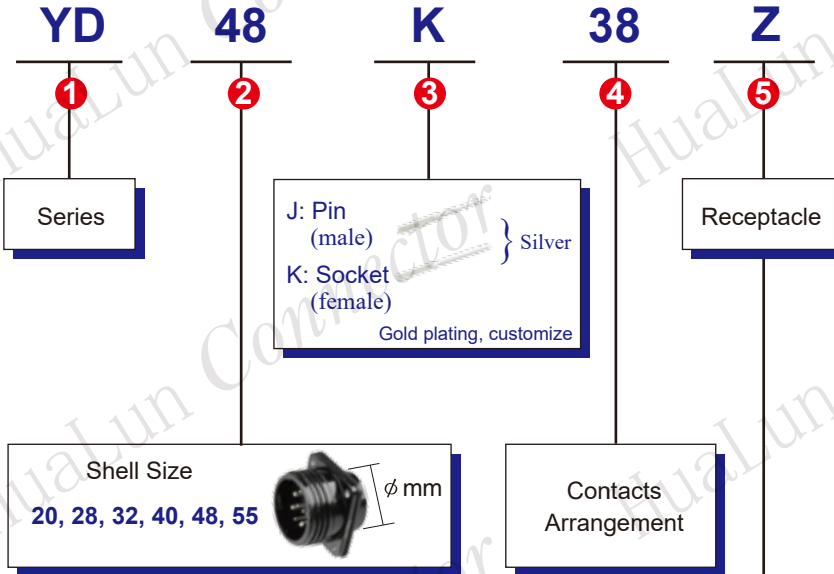



TUV SUD



ISO9001 ISO14001 ISO45001

Part Number (Explanation)

Receptacle ② (Protective Enclosure) (Clamp/Gland)

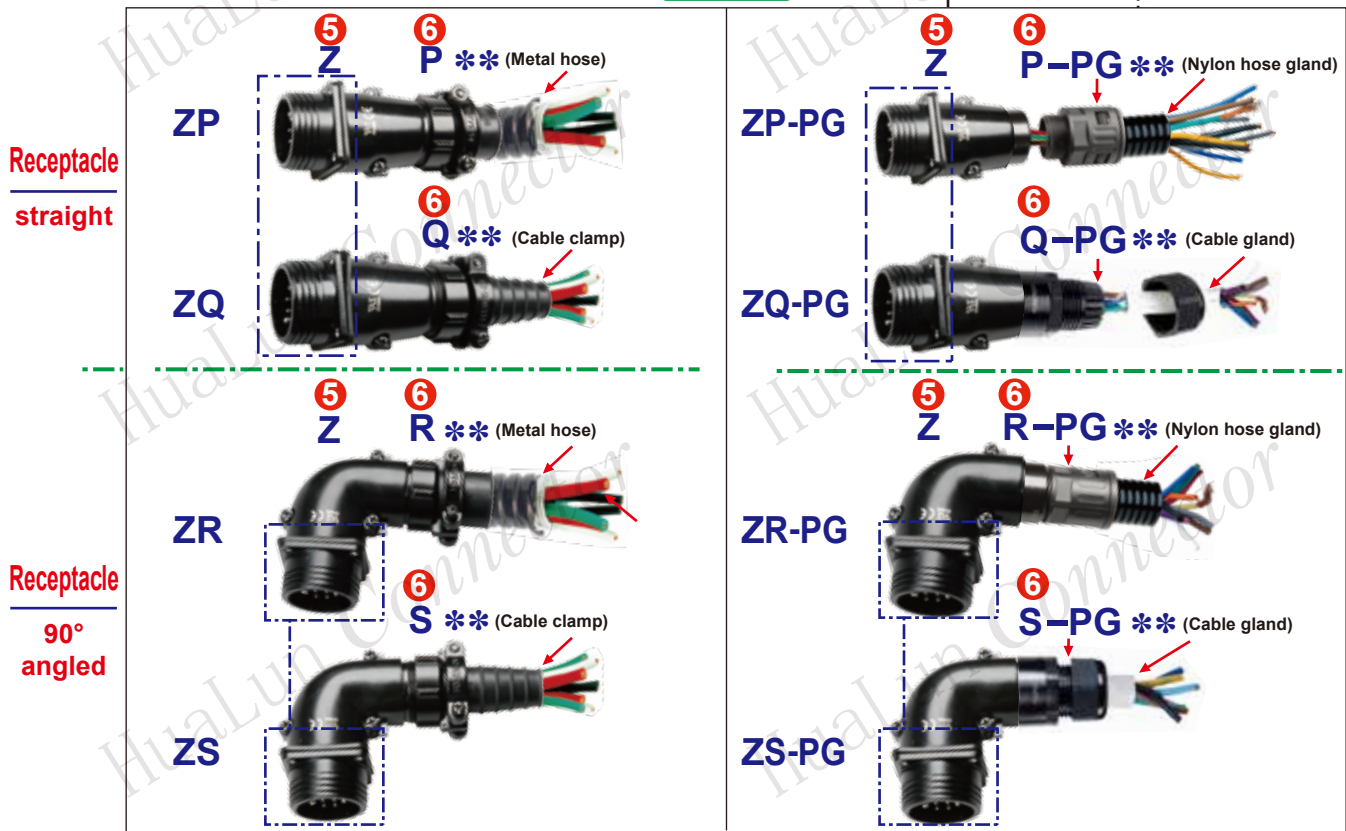
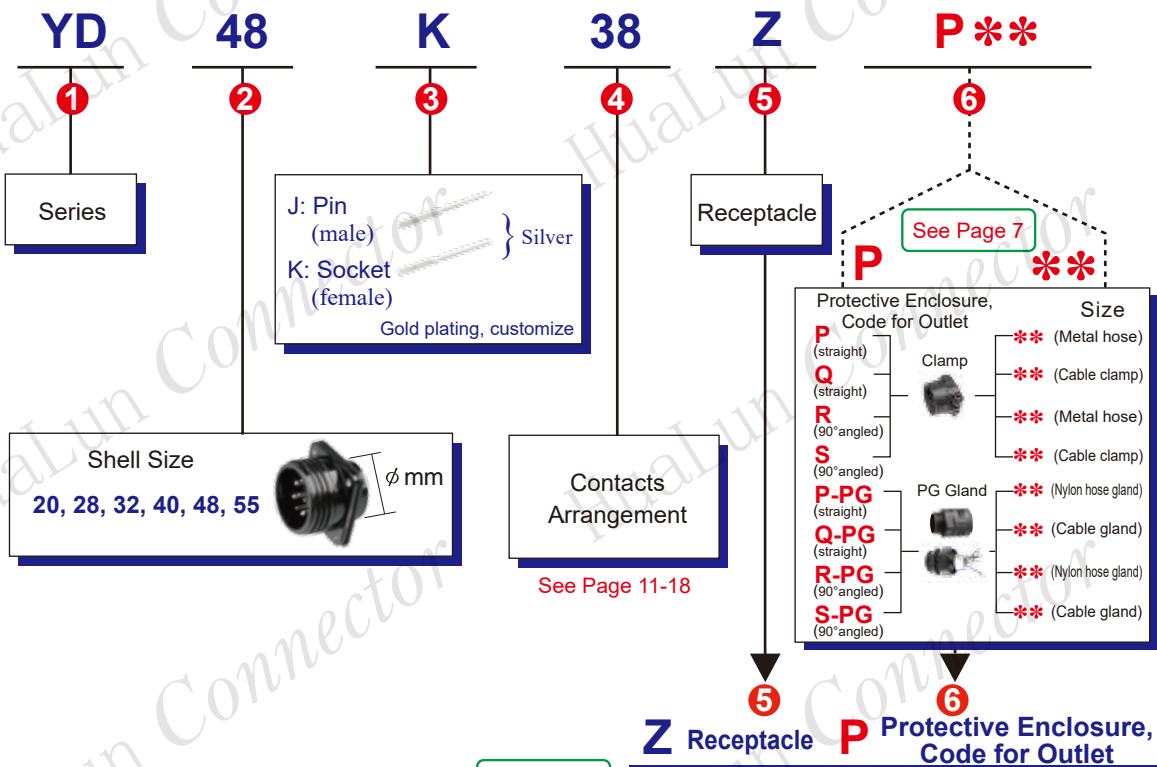

Receptacle-Protective Enclosure, Code for Outlet

ZP **



Code		Unit: mm
Shell Spec	ZP **	Inner diameter of metal hose accessory
20	ZP10	φ10
	ZP12	φ12
28	ZP12	φ12
	ZP15	φ15
32	ZP15	φ15
	ZP20	φ20
40	ZP20	φ20
	ZP25	φ25
48	ZP25	φ25
	ZP32	φ32
55	ZP32	φ32
	ZP38	φ38

ZR **



Code		Unit: mm
Shell Spec	ZR **	Inner diameter of metal hose accessory
20	ZR10	φ10
	ZR12	φ12
28	ZR12	φ12
	ZR15	φ15
32	ZR15	φ15
	ZR20	φ20
40	ZR20	φ20
	ZR25	φ25
48	ZR25	φ25
	ZR32	φ32
55	ZR32	φ32
	ZR38	φ38

ZP-PG **



Code		Unit: mm	
Shell Spec	ZP-PG **	ID	O.D
20	ZP-PG9	φ10	φ13
	ZP-PG11	φ12	φ15.8
28	ZP-PG11	φ12	φ15.8
	ZP-PG13.5	φ14.3	φ18.5
32	ZP-PG13.5	φ14.3	φ18.5
	ZP-PG16	φ17	φ21.2
40	ZP-PG16	φ17	φ21.2
	ZP-PG21	φ22	φ28.5
48	ZP-PG16	φ17	φ21.2
	ZP-PG21	φ22	φ28.5
55	ZP-PG29	φ28	φ34.5
	ZP-PG36	φ36	φ42.5

ZR-PG **



Code		Unit: mm	
Shell Spec	ZR-PG **	ID	O.D
20	ZR-PG9	φ10	φ13
	ZR-PG11	φ12	φ15.8
28	ZR-PG11	φ12	φ15.8
	ZR-PG13.5	φ14.3	φ18.5
32	ZR-PG13.5	φ14.3	φ18.5
	ZR-PG16	φ17	φ21.2
40	ZR-PG16	φ17	φ21.2
	ZR-PG21	φ22	φ28.5
48	ZR-PG16	φ17	φ21.2
	ZR-PG21	φ22	φ28.5
55	ZR-PG29	φ28	φ34.5
	ZR-PG36	φ36	φ42.5

ZQ **



Code		Unit: mm
Shell Spec	ZQ **	External diameter of cable
20	ZQ9	φ6~9
	ZQ12	φ9~12
28	ZQ12	φ9~12
	ZQ15	φ12~15
32	ZQ15	φ12~15
	ZQ20	φ15~20
40	ZQ20	φ15~20
	ZQ25	φ20~25
48	ZQ25	φ20~25
	ZQ32	φ25~32
55	ZQ32	φ25~32
	ZQ36	φ32~36

ZS **



Code		Unit: mm
Shell Spec	ZS **	External diameter of cable
20	ZS9	φ6~9
	ZS12	φ9~12
28	ZS12	φ9~12
	ZS15	φ12~15
32	ZS15	φ12~15
	ZS20	φ15~20
40	ZS20	φ15~20
	ZS25	φ20~25
48	ZS25	φ20~25
	ZS32	φ25~32
55	ZS32	φ25~32
	ZS38	φ32~36

ZQ-PG **



Code		Unit: mm
Shell Spec	ZQ-PG **	Cable gland O.D
20	ZQ-PG9	φ4~8
	ZQ-PG11	φ5~10
28	ZQ-PG11	φ5~10
	ZQ-PG13.5	φ6~12
32	ZQ-PG13.5	φ6~12
	ZQ-PG16	φ10~14
40	ZQ-PG16	φ10~14
	ZQ-PG21	φ13~18
48	ZQ-PG16	φ10~14
	ZQ-PG21	φ13~18
55	ZQ-PG29	φ18~25
	ZQ-PG36	φ22~32

ZS-PG **



Code		Unit: mm
Shell Spec	ZS-PG **	Cable gland O.D
20	ZS-PG9	φ4~8
	ZS-PG11	φ5~10
28	ZS-PG11	φ5~10
	ZS-PG13.5	φ6~12
32	ZS-PG13.5	φ6~12
	ZS-PG16	φ10~14
40	ZS-PG16	φ10~14
	ZS-PG21	φ13~18
48	ZS-PG16	φ10~14
	ZS-PG21	φ13~18
55	ZS-PG29	φ18~25
	ZS-PG36	φ22~32



TUV SUD



ISO9001 ISO14001 ISO45001

Part Number (Explanation)

Plug

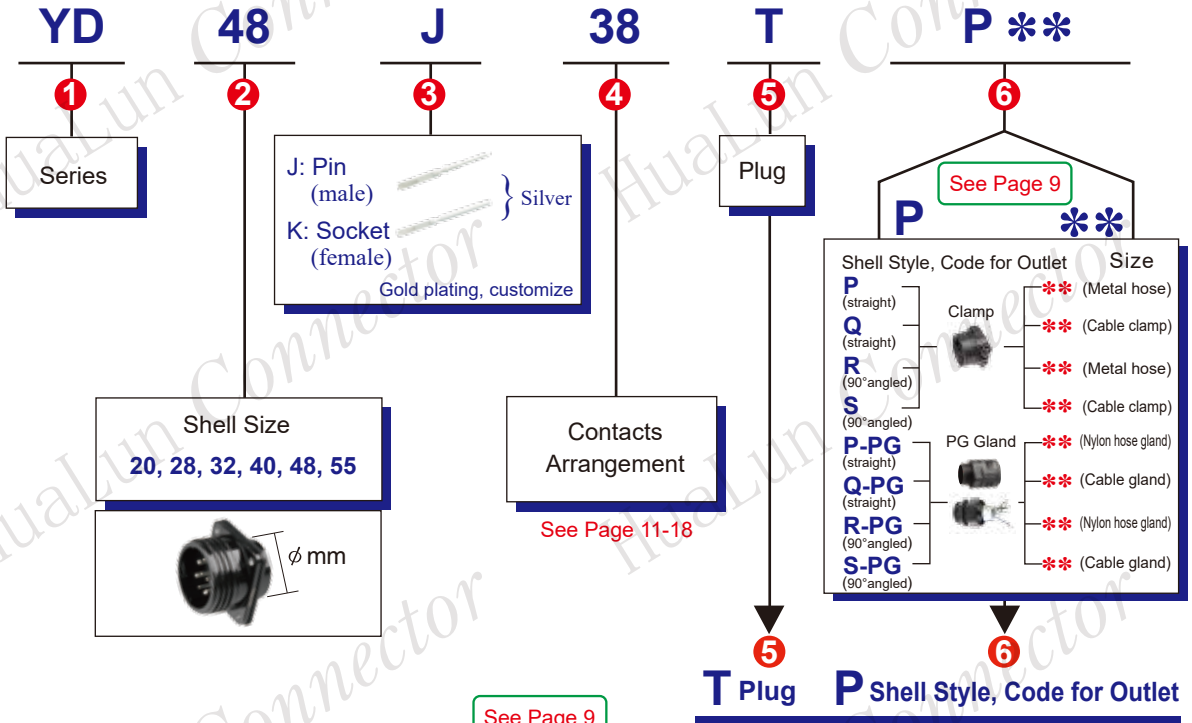

T Plug
straight

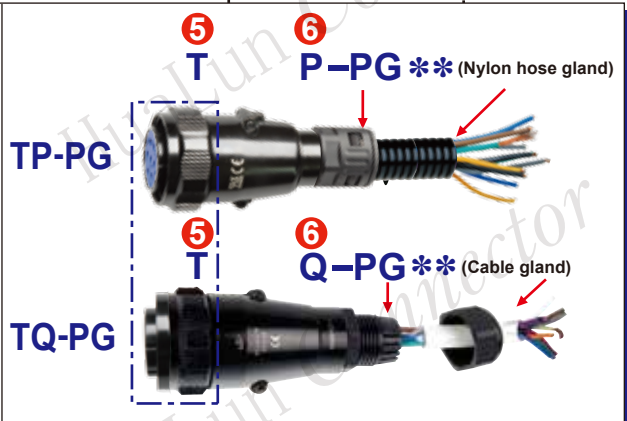
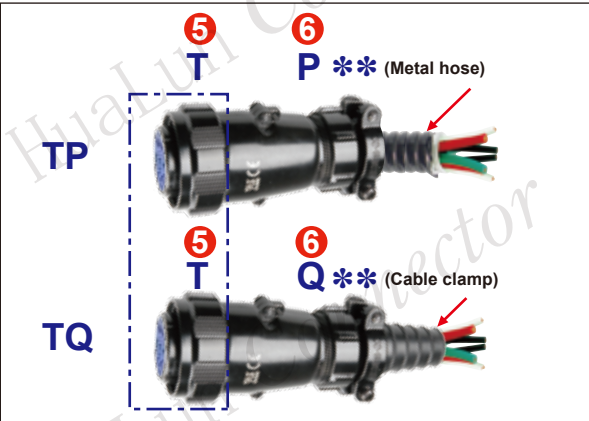

T Plug
90° angled

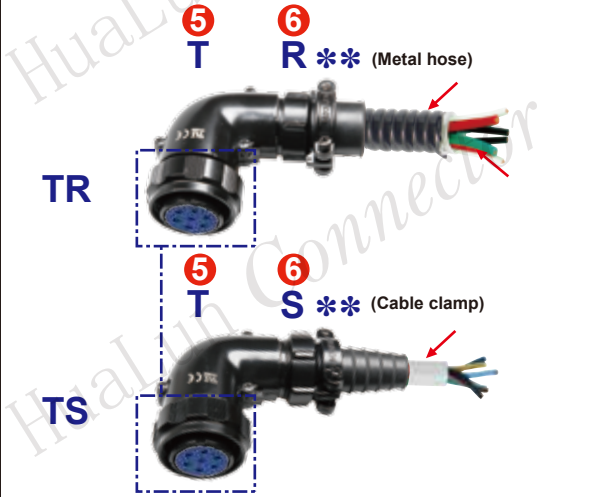

Plug-Shell Style, Code for Outlet

TP**



Code			Unit: mm
Shell Spec	TP**	Inner diameter of metal hose accessory	
20	TP10	φ10	
	TP12	φ12	
28	TP12	φ12	
	TP15	φ15	
32	TP15	φ15	
	TP20	φ20	
40	TP20	φ20	
	TP25	φ25	
48	TP25	φ25	
	TP32	φ32	
55	TP32	φ32	
	TP38	φ38	

TR**



Code			Unit: mm
Shell Spec	TR**	Inner diameter of metal hose accessory	
20	TR10	φ10	
	TR12	φ12	
28	TR12	φ12	
	TR15	φ15	
32	TR15	φ15	
	TR20	φ20	
40	TR20	φ20	
	TR25	φ25	
48	TR25	φ25	
	TR32	φ32	
55	TR32	φ32	
	TR38	φ38	

TP-PG**



Code				Unit: mm
Shell Spec	TP-PG**	ID	O.D	
20	TP-PG9	φ10	φ13	
	TP-PG11	φ12	φ15.8	
28	TP-PG11	φ12	φ15.8	
	TP-PG13.5	φ14.3	φ18.5	
32	TP-PG16	φ17	φ21.2	
	TP-PG13.5	φ14.3	φ18.5	
40	TP-PG16	φ17	φ21.2	
	TP-PG21	φ22	φ28.5	
48	TP-PG16	φ17	φ21.2	
	TP-PG21	φ22	φ28.5	
55	TP-PG29	φ28	φ34.5	
	TP-PG36	φ36	φ42.5	

TR-PG**



Code				Unit: mm
Shell Spec	TR-PG**	ID	O.D	
20	TR-PG9	φ10	φ13	
	TR-PG11	φ12	φ15.8	
28	TR-PG11	φ12	φ15.8	
	TR-PG13.5	φ14.3	φ18.5	
32	TR-PG16	φ17	φ21.2	
	TR-PG13.5	φ14.3	φ18.5	
40	TR-PG16	φ17	φ21.2	
	TR-PG21	φ22	φ28.5	
48	TR-PG16	φ17	φ21.2	
	TR-PG21	φ22	φ28.5	
55	TR-PG29	φ28	φ34.5	
	TR-PG36	φ36	φ42.5	

TQ**



Code			Unit: mm
Shell Spec	TQ**	External diameter of cable	
20	TQ9	φ6~9	
	TQ12	φ9~12	
28	TQ12	φ9~12	
	TQ15	φ12~15	
32	TQ15	φ12~15	
	TQ20	φ15~20	
40	TQ20	φ15~20	
	TQ25	φ20~25	
48	TQ25	φ20~25	
	TQ32	φ25~32	
55	TQ32	φ25~32	
	TQ36	φ32~36	

TS**



Code			Unit: mm
Shell Spec	TS**	External diameter of cable	
20	TS9	φ6~9	
	TS12	φ9~12	
28	TS12	φ9~12	
	TS15	φ12~15	
32	TS15	φ12~15	
	TS20	φ15~20	
40	TS20	φ15~20	
	TS25	φ20~25	
48	TS25	φ20~25	
	TS32	φ25~32	
55	TS32	φ25~32	
	TS38	φ32~36	

TQ-PG**



Code			Unit: mm
Shell Spec	TQ-PG**	Cable gland O.D	
20	TQ-PG9	φ4~8	
	TQ-PG11	φ5~10	
28	TQ-PG11	φ5~10	
	TQ-PG13.5	φ6~12	
32	TQ-PG16	φ10~14	
	TQ-PG13.5	φ6~12	
40	TQ-PG16	φ10~14	
	TQ-PG21	φ13~18	
48	TQ-PG16	φ10~14	
	TQ-PG21	φ13~18	
55	TQ-PG29	φ18~25	
	TQ-PG36	φ22~32	

TS-PG**



Code			Unit: mm
Shell Spec	TS-PG**	Cable gland O.D	
20	TS-PG9	φ4~8	
	TS-PG11	φ5~10	
28	TS-PG11	φ5~10	
	TS-PG13.5	φ6~12	
32	TS-PG16	φ10~14	
	TS-PG13.5	φ6~12	
40	TS-PG16	φ10~14	
	TS-PG21	φ13~18	
48	TS-PG16	φ10~14	
	TS-PG21	φ13~18	
55	TS-PG29	φ18~25	
	TS-PG36	φ22~32	



TUV SUD



TVV



ISO9001

ISO14001

ISO45001



华伦连接器
HuaLun Connector

Coupling Map of Receptacle (Panel Mounted) & Plug (Clamp)



Coupling Map of Receptacle (Panel Mounted) & Plug (PG Gland)



Shell Size - Arrangement No.

View from mating face

Pin: J K: Socket

Table 1

⊕: first mate/last break

● φ 1.5 ⊕ φ 2.5 ⊕ φ 3.5 φ: mm

Spec.	YD20					
Qty. of Contacts	2		3 (2+⊕)		4 (3+⊕)	
Contact Arrangement	Pin J2	K2 Socket	Pin J3	K3 Socket	Pin J4	K4 Socket
Contact Diameter×Qty.	φ 2.5 × 2		φ 2.5 × 2 + ⊕		φ 2.5 × 3 + ⊕	
Rated Current	⊕ 25A		⊕ 25A		⊕ 25A	
Rated Voltage	400V		400V		400V	
Rated Impulse Voltage	4000V		4000V		4000V	
Wire Gauge	<2.5mm ²		<2.5mm ²		<2.5mm ²	
Contact Resistance	<1mΩ		<1mΩ		<1mΩ	
Spec.	YD20					
Qty. of Contacts	5 (4+⊕)		5a (4+⊕)		7 (6+⊕)	
Contact Arrangement	Pin J5	K5 Socket	Pin J5a	K5a Socket	Pin J7	K7 Socket
Contact Diameter×Qty.	φ 1.5 × 4 + ⊕		φ 1.5 × 2	φ 2.5 × 2 + ⊕	φ 1.5 × 6 + ⊕	
Rated Current	● 10A		● 10A	⊕ 25A	● 10A	
Rated Voltage	250V		250V	400V	250V	
Rated Impulse Voltage	2500V		2500V	4000V	2500V	
Wire Gauge	<1.5mm ²		<1.5mm ²	<2.5mm ²	<1.5mm ²	
Contact Resistance	<2.5mΩ		<2.5mΩ	<1mΩ	<2.5mΩ	
Spec.	YD28					
Qty. of Contacts	4 (3+⊕)			4a (3+⊕)		
Contact Arrangement	Pin J4	K4 Socket	Pin J4a	K4a Socket	Pin J4a	K4a Socket
Contact Diameter×Qty.	φ 2.5 × 3 + ⊕			φ 2.5 (⊕)	φ 3.5 × 3	
Rated Current	⊕ 25A			⊕ 50A		
Rated Voltage	400V			400V		
Rated Impulse Voltage	4000V			4000V		
Wire Gauge	<2.5mm ²			<10mm ²		
Contact Resistance	<1mΩ			<0.5mΩ		



TUV SUD



ISO9001 ISO14001 ISO45001

华伦连接器
HuaLun Connector

Shell Size - Arrangement No.

View from mating face

Pin: J K: Socket

Table 2

⊕: first mate/last break

● ⊕ ⊖ φ: mm

Spec.	YD28			
Qty. of Contacts	5 (4+⊕)		7 (6+⊕)	
Contact Arrangement	Pin J5 	Socket K5 	Pin J7 	Socket K7
Contact Diameter×Qty.	φ 2.5 × 2		φ 3.5 × 2 + ⊕	
Rated Current	⊕ 25A		⊖ 50A	
Rated Voltage	250V		400V	
Rated Impulse Voltage	2500V		4000V	
Wire Gauge	<2.5mm ²		<10mm ²	
Contact Resistance	<1mΩ		<0.5mΩ	
Spec.	YD28			
Qty. of Contacts	10 (9+⊕)		11 (10+⊕)	
Contact Arrangement	Pin J10 	Socket K10 	Pin J11 	Socket K11
Contact Diameter×Qty.	φ 1.5 × 9 + ⊕		φ 1.5 × 8	
Rated Current	● 10A		● 10A	
Rated Voltage	250V		250V	
Rated Impulse Voltage	2500V		2500V	
Wire Gauge	<1.5mm ²		<1.5mm ²	
Contact Resistance	<2.5mΩ		<2.5mΩ	
Spec.	YD28			
Qty. of Contacts	15 (14+⊕)		17 (16+⊕)	
Contact Arrangement	Pin J15 	Socket K15 	Pin J17 	Socket K17
Contact Diameter×Qty.	φ 1.5 × 14 + ⊕		φ 1.5 × 16 + ⊕	
Rated Current	● 10A		● 10A	
Rated Voltage	250V		250V	
Rated Impulse Voltage	2500V		2500V	
Wire Gauge	<1.5mm ²		<1.5mm ²	
Contact Resistance	<2.5mΩ		<2.5mΩ	

Shell Size - Arrangement No.

View from mating face

Pin: J K: Socket

Table 3

⊕: first mate/last break

● φ 1.5 ⊕ φ 2.5 ⊕ φ 3.5 φ: mm

Spec.	YD32			
Qty. of Contacts	4 (3+⊕)		10 (9+⊕)	
Contact Arrangement	Pin J4	K4 Socket	Pin J10	K10 Socket
Contact Diameter×Qty.	φ 3.5 × 3 + ⊕		φ 1.5 × 6	φ 2.5 × 3 + ⊕
Rated Current	● 50A		● 10A	⊕ 25A
Rated Voltage	500V		250V	
Rated Impulse Voltage	4000V		2500V	
Wire Gauge	<10mm ²		<1.5mm ²	<2.5mm ²
Contact Resistance	<0.5mΩ		≤2.5mΩ	≤1mΩ
Spec.	YD32			
Qty. of Contacts	10a (9+⊕)		13 (12+⊕)	
Contact Arrangement	Pin J10a	K10a Socket	Pin J13	K13 Socket
Contact Diameter×Qty.	φ 1.5 × 5	φ 2.5 × 4 + ⊕	φ 1.5 × 9	φ 2.5 × 3 + ⊕
Rated Current	● 10A	⊕ 25A	● 10A	⊕ 25A
Rated Voltage	250V		250V	
Rated Impulse Voltage	2500V		2500V	
Wire Gauge	<1.5mm ²	<2.5mm ²	<1.5mm ²	<2.5mm ²
Contact Resistance	<2.5mΩ	≤1mΩ	≤2.5mΩ	≤1mΩ



TUV SUD



TUV



RoHS

ISO9001

ISO14001

ISO45001



华伦连接器

HuaLun Connector

Shell Size - Arrangement No.

View from mating face

Pin: J K: Socket

Table 4

⊕: first mate/last break

● ϕ 1.5 ⊕ ϕ 2.5 ⊗ ϕ 3.5 ϕ : mm

Spec.	YD32			
Qty. of Contacts	19 (18+⊕)			
Contact Arrangement	Pin	J19	K19	Socket
Contact Diameter×Qty.	ϕ 1.5 × 18 + ⊕			
Rated Current	● 10A			
Rated Voltage	250V			
Rated Impulse Voltage	2500V			
Wire Gauge	<1.5mm ²			
Contact Resistance	<2.5m Ω			
Spec.	YD40			
Qty. of Contacts	5 (4+⊕)		9 (8+⊕)	
Contact Arrangement	Pin	J5	K5	Socket
	Pin	J9	K9	Socket
Contact Diameter×Qty.	ϕ 3.5 × 4 + ⊕		ϕ 2.5 × 4 + ⊕	ϕ 3.5 × 4
Rated Current	⊗ 50A		⊕ 25A	⊗ 50A
Rated Voltage	500V		400V	
Rated Impulse Voltage	4000V		4000V	
Wire Gauge	<10mm ²		<2.5mm ²	<10mm ²
Contact Resistance	<0.5m Ω		<1m Ω	<0.5m Ω

Shell Size - Arrangement No.

View from mating face

Pin: J K: Socket

Table 5

⊕: first mate/last break

● φ 1.5 ⊕ φ 2.5 φ: mm

Spec.	YD40							
Qty. of Contacts	16 (15+⊕)		22 (21+⊕)					
Contact Arrangement	Pin	J16	K16	Socket	Pin	J22	K22	Socket
Contact Diameter×Qty.	φ 2.5 × 15 + ⊕		φ 1.5 × 18		φ 2.5 × 3 + ⊕			
Rated Current	⊕ 25A		● 10A		⊕ 25A			
Rated Voltage	250V		250V		250V			
Rated Impulse Voltage	2500V		2500V		2500V			
Wire Gauge	<2.5mm ²		<1.5mm ²		<2.5mm ²		<1.5mm ²	
Contact Resistance	<1mΩ		<2.5mΩ		<1mΩ		<2.5mΩ	
Spec.	YD40							
Qty. of Contacts	24 (23+⊕)		26 (25+⊕)					
Contact Arrangement	Pin	J24	K24	Socket	Pin	J26	K26	Socket
Contact Diameter×Qty.	φ 1.5 × 15		φ 2.5 × 8 + ⊕		φ 1.5 × 22		φ 2.5 × 3 + ⊕	
Rated Current	● 10A		⊕ 25A		● 10A		⊕ 25A	
Rated Voltage	250V		250V		250V			
Rated Impulse Voltage	2500V		2500V		2500V			
Wire Gauge	<1.5mm ²		<2.5mm ²		<1.5mm ²		<2.5mm ²	
Contact Resistance	<2.5mΩ		<1mΩ		<2.5mΩ		<1mΩ	



TUV SUD



TUV



ISO9001

ISO14001

ISO45001



华伦连接器

HuaLun Connector

Shell Size - Arrangement No.

View from mating face

Pin: J K: Socket

Table 6

⊕: first mate/last break

φ 1.5 φ 2.5 φ 3.5 φ 5.5 φ: mm

Spec.	YD40			
Qty. of Contacts	26a		31 (30 + ⊕)	
Contact Arrangement	Pin	J26a	K26a	Socket
	Pin	J31	K31	Socket
Contact Diameter × Qty.	φ 1.5 × 15		φ 2.5 × 11	
Rated Current	● 10A		⊕ 25A	
Rated Voltage	250V		250V	
Rated Impulse Voltage	2500V		2500V	
Wire Gauge	<1.5mm ²		<2.5mm ²	
Contact Resistance	<2.5mΩ		<1mΩ	
			φ 1.5 × 30 + ⊕	
			● 10A	
			250V	
			2500V	
			<1.5mm ²	
			<2.5mΩ	
Spec.	YD48			
Qty. of Contacts	5 (4 + ⊕)		7 (6 + ⊕)	
Contact Arrangement	Pin	J5	K5	Socket
	Pin	J7	K7	Socket
Contact Diameter × Qty.	φ 5.5 × 4 + ⊕		φ 3.5 × 6 + ⊕	
Rated Current	⊕ 100A		⊕ 50A	
Rated Voltage	500V		500V	
Rated Impulse Voltage	4000V		4000V	
Wire Gauge	<25mm ²		<10mm ²	
Contact Resistance	<0.3mΩ		<0.5mΩ	

Shell Size - Arrangement No.

View from mating face

Pin: **J** K: Socket

Table 7

⊕ : first mate/last break

● ⊕ ⊖
φ 1.5 φ 2.5 φ : mm

Spec.	YD48			
Qty. of Contacts	26		27 (26 + ⊕)	
Contact Arrangement	Pin J26	K26 Socket	Pin J27	K27 Socket
Contact Diameter×Qty.	φ 2.5 × 26		φ 1.5 × 26	φ 2.5 (⊕)
Rated Current	⊕ 25A		● 10A	
Rated Voltage	250V		250V	
Rated Impulse Voltage	2000V		2500V	
Wire Gauge	<2.5mm ²		<1.5mm ²	
Contact Resistance	<1mΩ		<2.5mΩ	
Spec.	YD48			
Qty. of Contacts	38 (37 + ⊕)		42 (41 + ⊕)	
Contact Arrangement	Pin J38	K38 Socket	Pin J42	K42 Socket
Contact Diameter×Qty.	φ 1.5 × 33	φ 2.5 × 4 + ⊕	φ 1.5 × 41	φ 2.5 (⊕)
Rated Current	● 10A	⊕ 25A	● 10A	
Rated Voltage	250V		250V	
Rated Impulse Voltage	2500V		2500V	
Wire Gauge	<1.5mm ²	<2.5mm ²	<1.5mm ²	
Contact Resistance	<2.5mΩ	<1mΩ	<2.5mΩ	



TUV SUD



TUV



ISO9001 ISO14001 ISO45001



华伦连接器
HuaLun Connector

Shell Size - Arrangement No.

View from mating face

Pin: J K: Socket

Table 8

⊕: first mate/last break

● φ 1.5 ⊕ φ 2.5 ⊕ φ 5.5 φ: mm

Spec.	YD55							
Qty. of Contacts	7 (6+⊕)		53 (52+⊕)					
Contact Arrangement	Pin	J7	K7	Socket	Pin	J53	K53	Socket
Contact Diameter×Qty.	φ 5.5 × 6 + ⊕		φ 1.5 × 48		φ 2.5 × 4 + ⊕			
Rated Current	● 100A		● 10A		⊕ 25A			
Rated Voltage	500V		250V		250V			
Rated Impulse Voltage	4000V		2500V		2500V			
Wire Gauge	<25mm ²		<1.5mm ²		<2.5mm ²			
Contact Resistance	<0.3mΩ		<2.5mΩ		<1mΩ			
Spec.	YD55							
Qty. of Contacts	61 (60+⊕)		86 (85+⊕)					
Contact Arrangement	Pin	J61	K61	Socket	Pin	J86	K86	Socket
Contact Diameter×Qty.	φ 1.5 × 60		φ 2.5 (⊕)		φ 1.5 × 85		φ 2.5 (⊕)	
Rated Current	● 10A		● 10A		● 10A			
Rated Voltage	250V		250V		250V			
Rated Impulse Voltage	2000V		2000V		2000V			
Wire Gauge	<1.5mm ²		<1.5mm ²		<1.5mm ²			
Contact Resistance	<2.5mΩ		<2.5mΩ		<2.5mΩ			

Size of Receptacle

Receptacle ① (Panel Mounted) (No Protective Enclosure)

YD Panel Mounted Receptacle

Z



Shell Spec	b	B	D0	D	L	N	G
20	22±0.2	32	20.5	M25×3	34	12	3
28	30±0.2	40	28	M33×3	34.5	12.5	
32	32±0.2	42	32	M38×3			
40	40±0.2	50	40	M46×3			
48	48±0.2	58	48	M55×3			
55	52±0.2	64	55	M62×3	12	3.5	

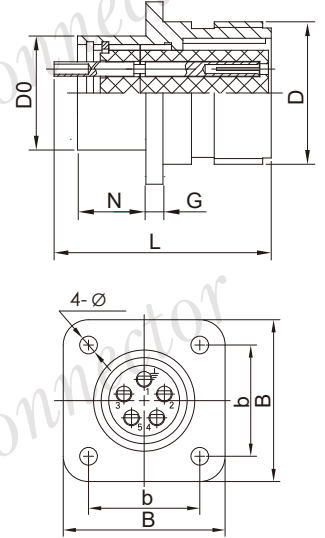

Receptacle Mounting & Mounting Hole

● Front Mounting

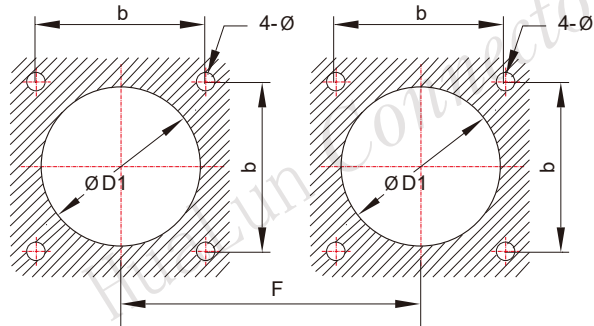
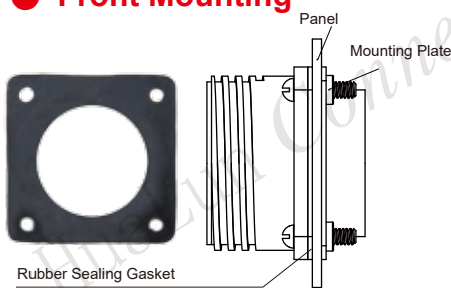

● Rear Mounting

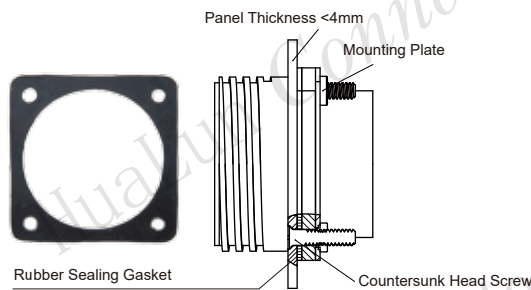

If it is rear-mounted, please specify when ordering, we provide rear-mounted rubber sealing gasket

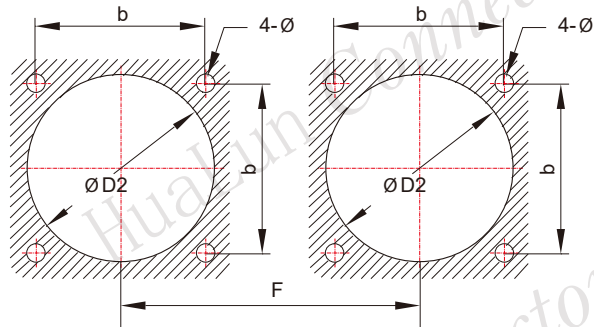

Mounting Hole Dimension

Unit: mm

Shell Spec	4-Ø	ØD1	ØD2	b	F
20	3.50	Ø21.00	Ø25.50	22±0.2	52.00
28		Ø28.50	Ø33.50	30±0.2	62.00
32		Ø32.50	Ø38.50	32±0.2	67.00
40		Ø41.00	Ø47.00	40±0.2	80.00
48	4.50	Ø49.00	Ø56.00	48±0.2	90.00
55		Ø56.00	Ø63.00	52±0.2	102.00



TUV SUD



TVV



ISO9001

ISO14001

ISO45001



华伦连接器

HuaLun Connector

Size of Receptacle

Receptacle ② (Protective Enclosure) (Clamp/Gland)

● ZP - Straight, Protective Enclosure Receptacle

● ZQ - Straight, Protective Enclosure Receptacle

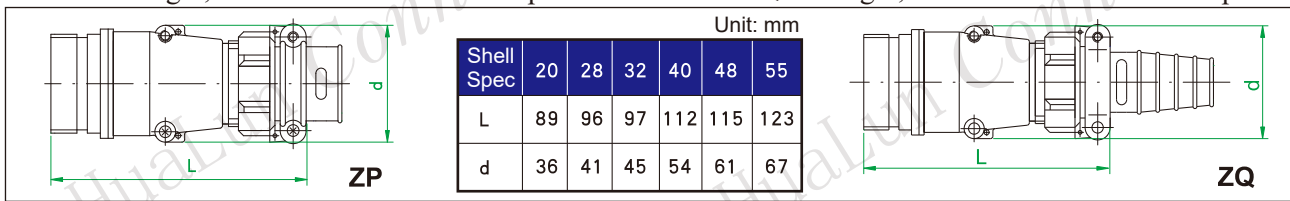

● ZR - (90° angled), Protective Enclosure Receptacle

● ZS - (90° angled), Protective Enclosure Receptacle

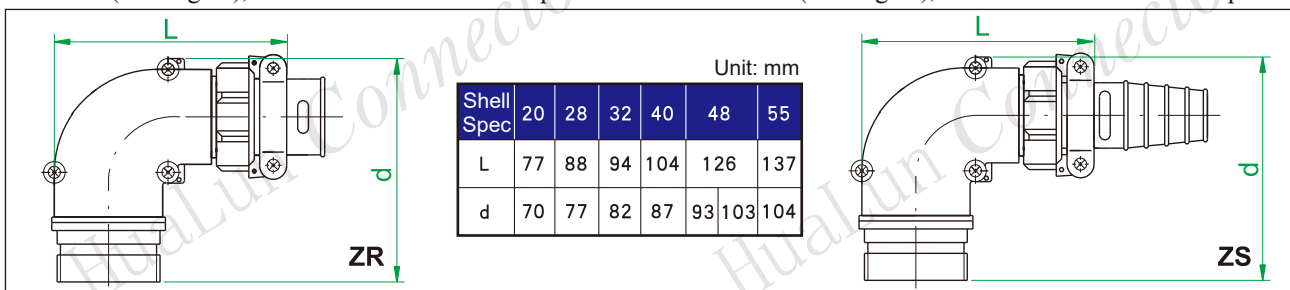

● ZP-PG Nylon hose gland

● ZQ-PG Cable gland

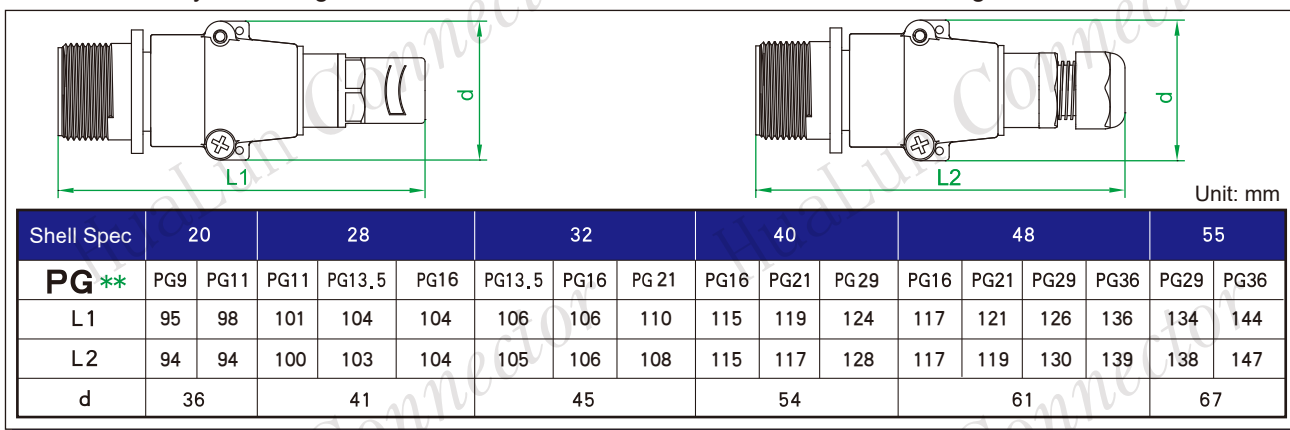

● ZR-PG Nylon hose gland

● ZS-PG Cable gland

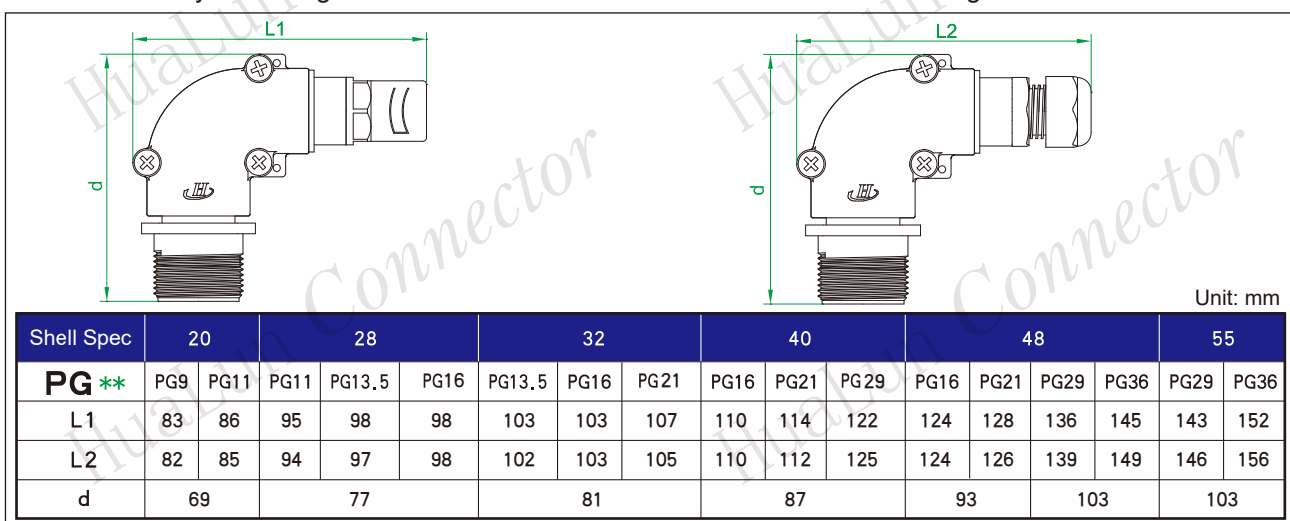

Size of Plug

Plug

● **TP** - Metal hose

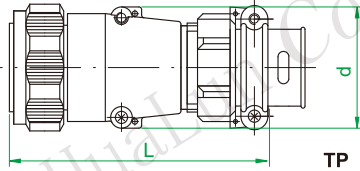

Unit: mm

Shell Spec	20	28	32	40	48	55
L	87	94	95	110	113	121
d	36	41	45	54	61	67

● **TQ** - Cable clamp

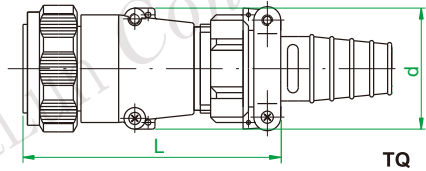

● **TR** - Metal hose

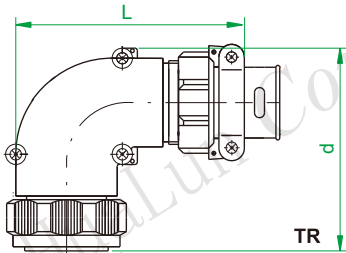

Unit: mm

Shell Spec	20	28	32	40	48	55
L	77	88	94	104	126	137
d	68	76	80	86	92	102

● **TS** - Cable clamp

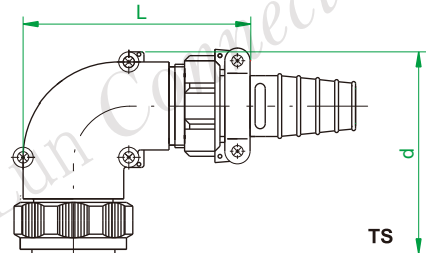

● **TP-PG** Nylon hose gland

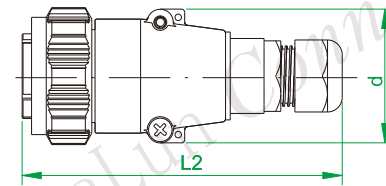
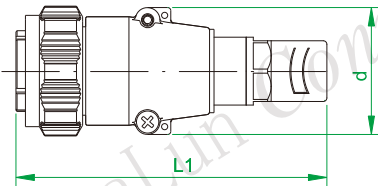

Unit: mm

Shell Spec	20			28			32			40			48				55	
PG **	PG9	PG11	PG11	PG13,5	PG16	PG13,5	PG16	PG21	PG16	PG21	PG29	PG16	PG21	PG29	PG36	PG29	PG36	
L1	94	97	100	103	103	105	105	109	114	118	123	116	120	125	135	133	143	
L2	93	93	99	102	103	104	105	109	114	116	125	116	118	129	138	137	146	
d	36			41			45			54			61				67	

● **TR-PG** Nylon hose gland

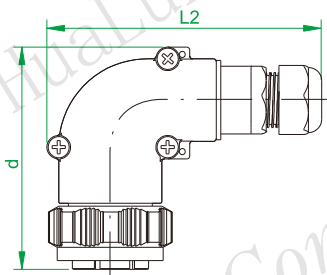
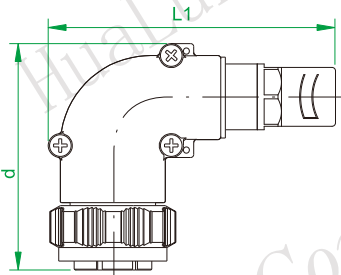

Unit: mm

Shell Spec	20			28			32			40			48				55	
PG **	PG9	PG11	PG11	PG13,5	PG16	PG13,5	PG16	PG21	PG16	PG21	PG29	PG16	PG21	PG29	PG36	PG29	PG36	
L1	83	86	95	98	98	103	103	107	110	114	122	124	128	136	145	143	152	
L2	82	85	94	97	98	102	103	105	110	112	125	124	126	139	149	146	156	
d	68			76			80			86			92				102	



TUV SUD



ISO9001

ISO14001

ISO45001

Accessories

1 Mounting Plate

Technical advantages: (1) Convenient and Fast (2) Firm

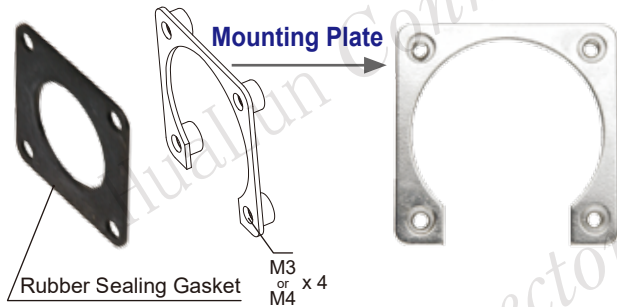
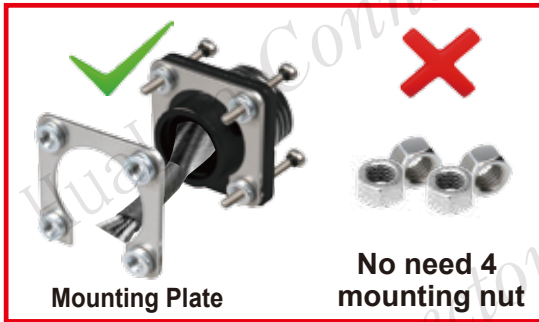

Mounting Plate Order Code, Size

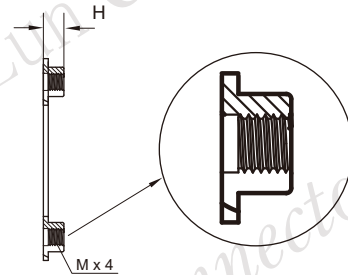
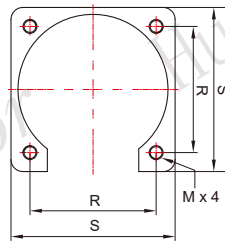
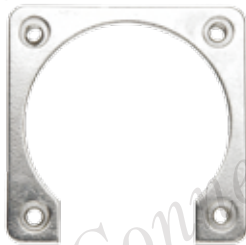

Unit: mm

Code	Shell Size	R	S	H	Thread M	Screw Spec
A20	20	22.00	30.00	2.60	M3	M3 x 10
A28	28	30.00	40.00			
A32	32	32.00	42.00			
A40	40	40.00	50.00	3.00	M4	M4 x 10
A48	48	48.00	58.00			
A55	55	52.00	64.00			

2 Plug Protection Cap



Dust Cap Code	Application
YD20-TG	Shell 20 Plug
YD28-TG	Shell 28 Plug
YD32-TG	Shell 32 Plug
YD40-TG	Shell 40 Plug
YD48-TG	Shell 48 Plug
YD55-TG	Shell 55 Plug

3 Receptacle Protection Cap



Dust Cap Code	Application
YD20-ZG	Shell 20 Receptacle
YD28-ZG	Shell 28 Receptacle
YD32-ZG	Shell 32 Receptacle
YD40-ZG	Shell 40 Receptacle
YD48-ZG	Shell 48 Receptacle
YD55-ZG	Shell 55 Receptacle



SHANGHAI HUALUN INSTRUMENTS & ELECTRONICS CO., LTD.

SALES & MARKETING DEPARTMENT

ADD: Rm3409, Tower2, Kerry Everbright City, West
Tianmu Rd218, Shanghai

P.C. : 200070

TEL : 86-21-63178300 ext. 205

FAX : 86-21-63178083

E-MAIL : liz@hualunconnector.com

WEB : www.hualunconnector.com

FACTORY & HEADQUARTERS

ADD: Factory building 1 & 3, Jinjiang Industrial
Park, Qianyang Rd271, Shanghai

P.C. : 200333

- Hualun reserves the right to modify the technical and upgrade of the product
- Any form of diversion of this cataloge must be authorized by Hualun