

YDK Circular Connector

- Coupling: Bayonet
- Terminal: Crimp



Extract from the backend
Crimp contacts



Index

Profile	2
Assemble Parts, Crimp, Insertion & Extraction	3
Technical Data	4
Part Number Explanation	5-14
Receptacle	5-7
Receptacle① (Panel Mounted, No Protective Enclosure)	5
Receptacle② (Protective Enclosure, Clamp/Gland)	6
Receptacle-Protective Enclosure, Code for Outlet	7
Plug	8-9
Plug-Shell Style, Code for Outlet	9
Contacts Arrangement	10-13
Contacts, Tools	14
Size of Receptacle & Plug	15-17
Receptacle① (Panel Mounted, No Protective Enclosure) , Receptacle Mounting & Mounting Hole	15
Receptacle② (Protective Enclosure, Clamp/Gland)	16
Plug	17
Accessories	18

Profile

Design standard: IEC61984 & VG95234.

Technical Data:

- ① Coupling: bayonet ② Terminal: crimp ③ Equipped with lengthened grounding pin in first mate/last break structure.
- ◆ Shell Spec: 20, 28, 32, 40, 48, 55.
- ◆ No. of Contacts: 2-53pins, more than 50 spec.
- ◆ Plug: ① straight ② 90° angled
- ◆ Four types of outlets.
- ◆ Our products conform to German TUV, America UL, European CE and passed the RoHS test.
- ◆ Degree of protection: IP65
- ◆ The products are used for electrical circuit connection and signal transmission of various mechanical equipment

Hualun connectors are appointed by Chinese rail transport, engineering machinery, power electric power, thermoplastic machinery, industrial automation, and robot manufacturing enterprises. as a perennial supporting product.



High-tech Enterprise Certificate



Foreign Invested Advanced



Enterprise Credit Rating AAA



Software Copyright



ISO9001, ISO14001, ISO45001



UL for YD series

Live parts should not be disassembled without authorization!!!



Crimp, Insertion & Extraction

Insertion

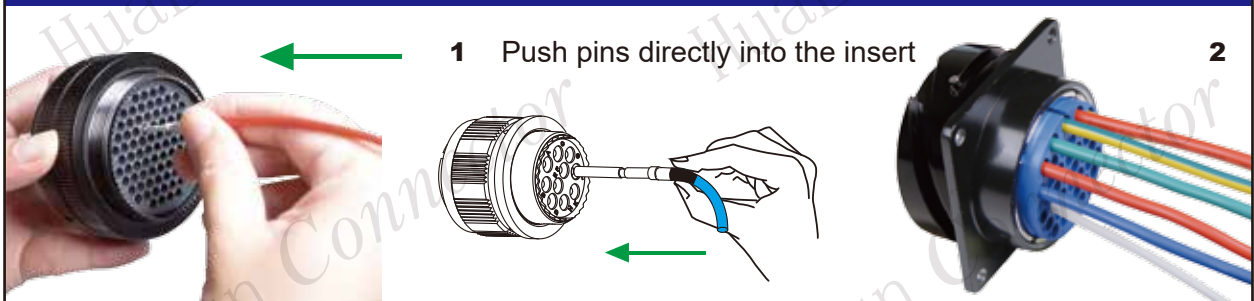

Extraction



Technical Data

● Environmental, Mechanical Features

Operating Temperature	Upper limit+125°C *1
	Lower limit-55°C *2
Relative Humidity	93%~95% at 40°C±2°C
Salty Spray Corrosion	≥96h
Protection Degree	IP65/IP67 (when mated,wired and mounted according to DS)
Shock Vibration	Class 1B (GB/T21563-2018)
Mechanical Life	≥500

Note:*1 The upper limit temperature is the maximum internal hot spot temperature that occurs in either combination of electrical load and environmental conditions.

*2 The minimum allowable operating temperature value of the connector according to the defined climate category (upper and lower limit temperatures and damp heat test time, as defined in the climate category in GB/T2421.1)

● Electric Features

Degree of Pollution	2/3	Overtoltage Category	II / III
Insulation Resistance	Normal: ≥5000MΩ, (Dynamic values see tableA)		
Contact Diameter (mm)	φ 1.5	φ 2.5	
Rated Current	10A	25A	
Rated Voltage	See Contacts Arrangement Page10~13		
Rated Impulse Voltage			
Wire Gauge			
Contact Resistance			
Remark: For High Altitude Low Pressure Environment Refer to GB/T4797.2-2005			

TableA The limit value of insulation resistance varies with temperature

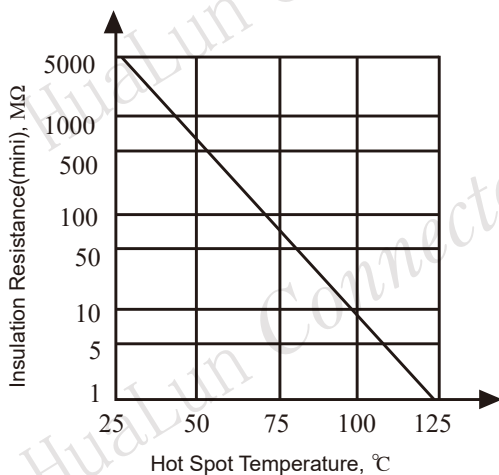

Current-Carrying Capacity Curve (IEC/EN 60512-5)

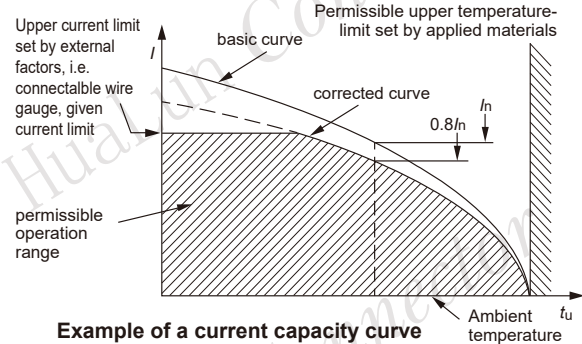

Example of a current capacity curve

- ◆ The rated current is the continuous, not interrupted current a connector can take when simultaneous power on all contacts is given, without exceeding the maximum temperature.
- ◆ For the rated current of multi-pin connectors, the derating should be shown according to the "derating curve" graph. For the derating rate, please refer to the table below

Contact current De-rating

Qty of contacts	1~10	11~20	21~30	31~50	51~80
Drop rate%	0	10	20	30	40

● Material: RoHS

Shell	Aluminum Alloy (Electrophoresis, Black)
Contact	Copper Alloys (Silver) Gold plating, customize
Insert	Plastic UL Certificate
	Flame Resistance UL94V-0

Dielectric Strength Test Voltage

Rated Impulse Voltage (U _{imp}) kV	Test voltage-Pulse Withstand Voltage kV(1.2/50μs)		Withstand Voltage Test (r.m.s) kV(50/60Hz)
	Altitude 2000m	Sea Level	
0.5	0.5	0.55	0.37
0.8	0.8	0.91	0.50
1.5	1.5	1.75	0.84
2.5	2.5	2.95	1.39
4	4	4.8	2.21

Testing Condition

Temperature: 15°C~35°C	Relative Humidity: 20%~80%	Atmospheric Pressure: 73KPa~106KPa
------------------------	----------------------------	------------------------------------

— Part Number —

(Explanation)

Receptacle ① (Panel Mounted)
(No Protective Enclosure)

YDK

48

YK

38

Z

①

②

③

④

⑤

Series

Y: Crimp
J: Pin (male)
K: Socket (female)
} Silver
Gold plating, customize

Receptacle

See Page 14

Shell Size

20, 28, 32, 40, 48, 55

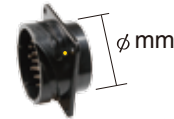

Contacts Arrangement

See Page 10-13

(female) K: Socket

(male) J: Pin



(female) Insert



(male) Insert



TUV SUD



ISO9001 ISO14001 ISO45001

Part Number (Explanation)

Receptacle ② (Protective Enclosure)
(Clamp/Gland)

YDK **48** **YK** **38** **Z** **P*****

Series

Y: Crimp
J: Pin (male)
K: Socket (female)
} Silver
Gold plating, customize
See Page 14

Shell Size
20, 28, 32, 40, 48, 55
∅ mm

Contacts Arrangement
See Page 10-13

Receptacle

See Page 7

Protective Enclosure, Code for Outlet		Size
P (straight)	Clamp	*** (Metal hose)
Q (straight)	Clamp	*** (Cable clamp)
R (90° angled)	Clamp	*** (Metal hose)
S (90° angled)	Clamp	*** (Cable clamp)
P-PG (straight)	PG Gland	*** (Nylon hose gland)
Q-PG (straight)	PG Gland	*** (Cable gland)
R-PG (90° angled)	PG Gland	*** (Nylon hose gland)
S-PG (90° angled)	PG Gland	*** (Cable gland)

Z Receptacle **P** Protective Enclosure, Code for Outlet

See Page 7

Receptacle straight

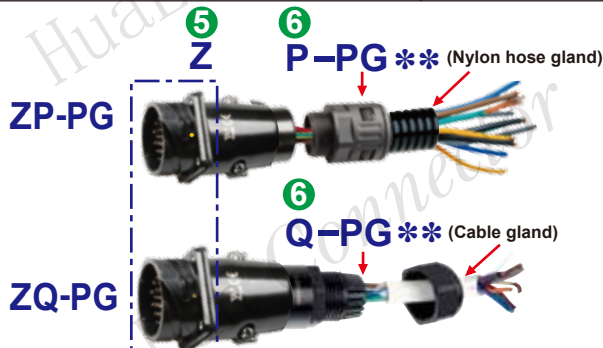
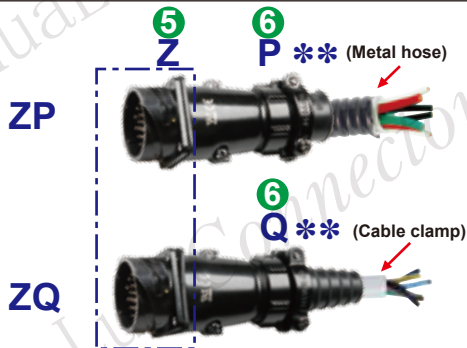

Receptacle 90° angled

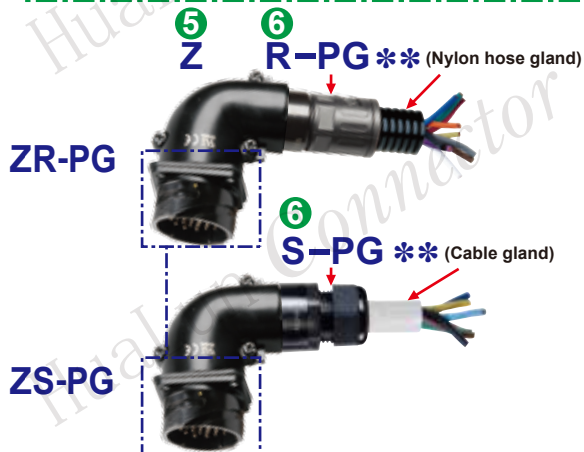
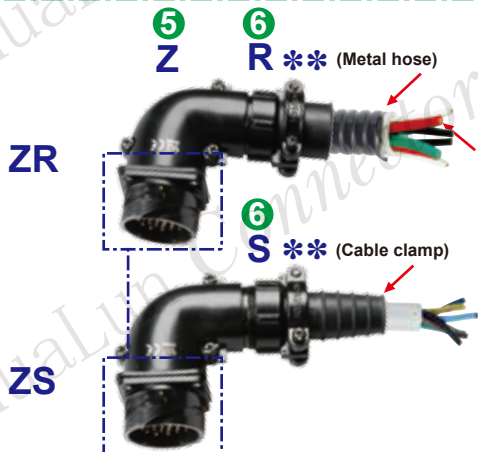

Receptacle-Protective Enclosure, Code for Outlet

ZP **



Code		Unit: mm
Shell Spec.	ZP **	Inner diameter of metal hose accessory
20	ZP10	φ10
	ZP12	φ12
28	ZP12	φ12
	ZP15	φ15
32	ZP15	φ15
	ZP20	φ20
40	ZP20	φ20
	ZP25	φ25
48	ZP25	φ25
	ZP32	φ32
55	ZP32	φ32
	ZP38	φ38

ZR **



Code		Unit: mm
Shell Spec.	ZR **	Inner diameter of metal hose accessory
20	ZR10	φ10
	ZR12	φ12
28	ZR12	φ12
	ZR15	φ15
32	ZR15	φ15
	ZR20	φ20
40	ZR20	φ20
	ZR25	φ25
48	ZR25	φ25
	ZR32	φ32
55	ZR32	φ32
	ZR38	φ38

ZP-PG **



Code		Unit: mm	
Shell Spec.	ZP-PG **	ID	O.D
20	ZP-PG9	φ10	φ13
	ZP-PG11	φ12	φ15.8
28	ZP-PG11	φ12	φ15.8
	ZP-PG13.5	φ14.3	φ18.5
32	ZP-PG16	φ17	φ21.2
	ZP-PG13.5	φ14.3	φ18.5
40	ZP-PG16	φ17	φ21.2
	ZP-PG21	φ22	φ28.5
48	ZP-PG16	φ17	φ21.2
	ZP-PG21	φ22	φ28.5
55	ZP-PG29	φ28	φ34.5
	ZP-PG36	φ36	φ42.5

ZR-PG **



Code		Unit: mm	
Shell Spec.	ZR-PG **	ID	O.D
20	ZR-PG9	φ10	φ13
	ZR-PG11	φ12	φ15.8
28	ZR-PG11	φ12	φ15.8
	ZR-PG13.5	φ14.3	φ18.5
32	ZR-PG16	φ17	φ21.2
	ZR-PG13.5	φ14.3	φ18.5
40	ZR-PG16	φ17	φ21.2
	ZR-PG21	φ22	φ28.5
48	ZR-PG16	φ17	φ21.2
	ZR-PG21	φ22	φ28.5
55	ZR-PG29	φ28	φ34.5
	ZR-PG36	φ36	φ42.5

ZQ **



Code		Unit: mm
Shell Spec.	ZQ **	External diameter of cable
20	ZQ9	φ6~9
	ZQ12	φ9~12
28	ZQ12	φ9~12
	ZQ15	φ12~15
32	ZQ15	φ12~15
	ZQ20	φ15~20
40	ZQ20	φ15~20
	ZQ25	φ20~25
48	ZQ25	φ20~25
	ZQ32	φ25~32
55	ZQ32	φ25~32
	ZQ36	φ32~36

ZS **



Code		Unit: mm
Shell Spec.	ZS **	External diameter of cable
20	ZS9	φ6~9
	ZS12	φ9~12
28	ZS12	φ9~12
	ZS15	φ12~15
32	ZS15	φ12~15
	ZS20	φ15~20
40	ZS20	φ15~20
	ZS25	φ20~25
48	ZS25	φ20~25
	ZS32	φ25~32
55	ZS32	φ25~32
	ZS38	φ32~36

ZQ-PG **



Code		Unit: mm
Shell Spec.	ZQ-PG **	Cable gland O.D
20	ZQ-PG9	φ4~8
	ZQ-PG11	φ5~10
28	ZQ-PG11	φ5~10
	ZQ-PG13.5	φ6~12
32	ZQ-PG16	φ10~14
	ZQ-PG13.5	φ6~12
40	ZQ-PG16	φ10~14
	ZQ-PG21	φ13~18
48	ZQ-PG16	φ10~14
	ZQ-PG21	φ13~18
55	ZQ-PG29	φ18~25
	ZQ-PG36	φ22~32

ZS-PG **



Code		Unit: mm
Shell Spec.	ZS-PG **	Cable gland O.D
20	ZS-PG9	φ4~8
	ZS-PG11	φ5~10
28	ZS-PG11	φ5~10
	ZS-PG13.5	φ6~12
32	ZS-PG16	φ10~14
	ZS-PG13.5	φ6~12
40	ZS-PG16	φ10~14
	ZS-PG21	φ13~18
48	ZS-PG16	φ10~14
	ZS-PG21	φ13~18
55	ZS-PG29	φ18~25
	ZS-PG36	φ22~32



TUV SUD



ISO9001 ISO14001 ISO45001

Part Number (Explanation)

Plug

YDK **48** **YJ** **38** **T** **P ****

1 Series

2 Shell Size
20, 28, 32, 40, 48, 55

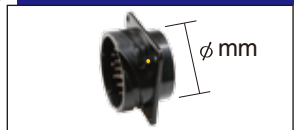

3 Y: Crimp
J: Pin (male)
K: Socket (female)
Silver
Gold plating, customize

See Page 14

4 Contacts Arrangement

See Page 10-13

5 Plug

6 See Page 9

Shell Style, Code for Outlet	Size
P (straight)	** (Metal hose)
Q (straight)	** (Cable clamp)
R (90° angled)	** (Metal hose)
S (90° angled)	** (Cable clamp)
P-PG (straight)	** (Nylon hose gland)
Q-PG (straight)	** (Cable gland)
R-PG (90° angled)	** (Nylon hose gland)
S-PG (90° angled)	** (Cable gland)

5 **T Plug** 6 **P Shell Style, Code for Outlet**

See Page 9

T Plug
straight

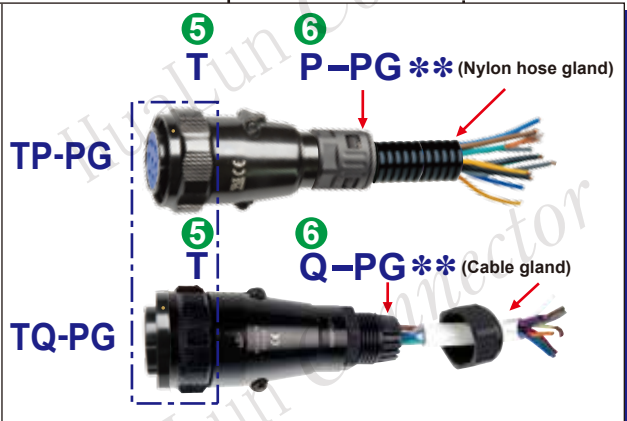
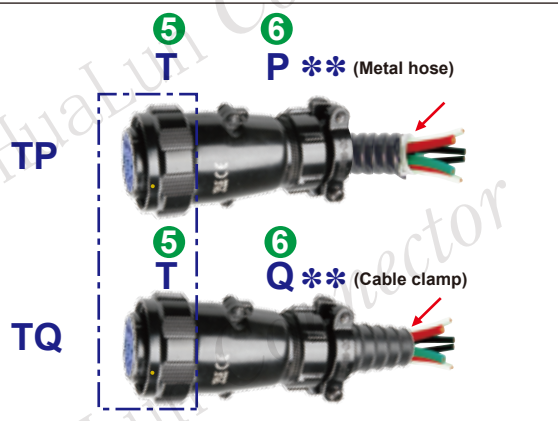

T Plug
90° angled

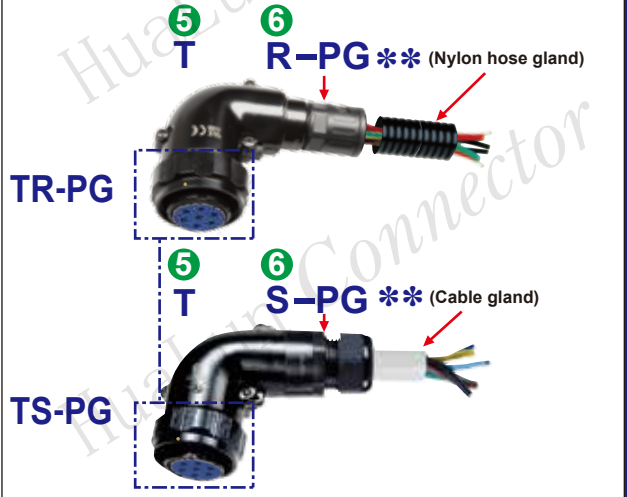
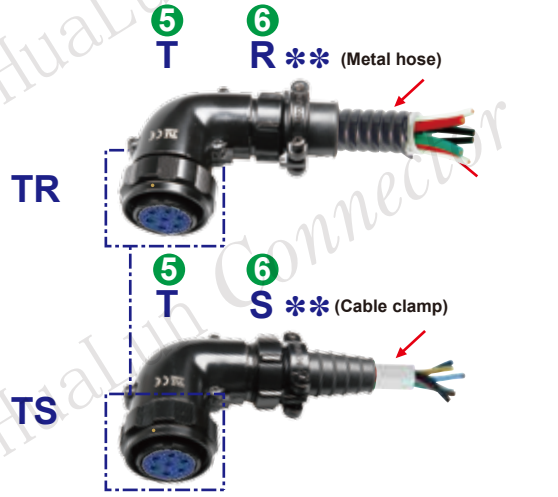

Plug-Shell Style, Code for Outlet

TP **



Code		Unit: mm
Shell Spec	TP**	Inner diameter of metal hose accessory
20	TP10	φ10
	TP12	φ12
28	TP12	φ12
	TP15	φ15
32	TP15	φ15
	TP20	φ20
40	TP20	φ20
	TP25	φ25
48	TP25	φ25
	TP32	φ32
55	TP32	φ32
	TP38	φ38

TR **



Code		Unit: mm
Shell Spec	TR**	Inner diameter of metal hose accessory
20	TR10	φ10
	TR12	φ12
28	TR12	φ12
	TR15	φ15
32	TR15	φ15
	TR20	φ20
40	TR20	φ20
	TR25	φ25
48	TR25	φ25
	TR32	φ32
55	TR32	φ32
	TR38	φ38

TP-PG **



Code		Unit: mm	
Shell Spec	TP-PG**	ID	O.D
20	TP-PG9	φ10	φ13
	TP-PG11	φ12	φ15.8
28	TP-PG11	φ12	φ15.8
	TP-PG13.5	φ14.3	φ18.5
	TP-PG16	φ17	φ21.2
32	TP-PG13.5	φ14.3	φ18.5
	TP-PG16	φ17	φ21.2
	TP-PG21	φ22	φ28.5
40	TP-PG16	φ17	φ21.2
	TP-PG21	φ22	φ28.5
	TP-PG29	φ28	φ34.5
48	TP-PG16	φ17	φ21.2
	TP-PG21	φ22	φ28.5
	TP-PG29	φ28	φ34.5
55	TP-PG29	φ28	φ34.5
	TP-PG36	φ36	φ42.5

TR-PG **



Code		Unit: mm	
Shell Spec	TR-PG**	ID	O.D
20	TR-PG9	φ10	φ13
	TR-PG11	φ12	φ15.8
28	TR-PG11	φ12	φ15.8
	TR-PG13.5	φ14.3	φ18.5
	TR-PG16	φ17	φ21.2
32	TR-PG13.5	φ14.3	φ18.5
	TR-PG16	φ17	φ21.2
	TR-PG21	φ22	φ28.5
40	TR-PG16	φ17	φ21.2
	TR-PG21	φ22	φ28.5
	TR-PG29	φ28	φ34.5
48	TR-PG16	φ17	φ21.2
	TR-PG21	φ22	φ28.5
	TR-PG29	φ28	φ34.5
55	TR-PG29	φ28	φ34.5
	TR-PG36	φ36	φ42.5

TQ **



Code		Unit: mm
Shell Spec	TQ**	External diameter of cable
20	TQ9	φ6~9
	TQ12	φ9~12
28	TQ12	φ9~12
	TQ15	φ12~15
32	TQ15	φ12~15
	TQ20	φ15~20
40	TQ20	φ15~20
	TQ25	φ20~25
48	TQ25	φ20~25
	TQ32	φ25~32
55	TQ32	φ25~32
	TQ36	φ32~36

TS **



Code		Unit: mm
Shell Spec	TS**	External diameter of cable
20	TS9	φ6~9
	TS12	φ9~12
28	TS12	φ9~12
	TS15	φ12~15
32	TS15	φ12~15
	TS20	φ15~20
40	TS20	φ15~20
	TS25	φ20~25
48	TS25	φ20~25
	TS32	φ25~32
55	TS32	φ25~32
	TS38	φ32~36

TQ-PG **



Code		Unit: mm
Shell Spec	TQ-PG**	Cable gland O.D
20	TQ-PG9	φ4~8
	TQ-PG11	φ5~10
28	TQ-PG11	φ5~10
	TQ-PG13.5	φ6~12
	TQ-PG16	φ10~14
32	TQ-PG13.5	φ6~12
	TQ-PG16	φ10~14
	TQ-PG21	φ13~18
40	TQ-PG16	φ10~14
	TQ-PG21	φ13~18
	TQ-PG29	φ18~25
48	TQ-PG16	φ10~14
	TQ-PG21	φ13~18
	TQ-PG29	φ18~25
55	TQ-PG29	φ18~25
	TQ-PG36	φ22~32

TS-PG **



Code		Unit: mm
Shell Spec	TS-PG**	Cable gland O.D
20	TS-PG9	φ4~8
	TS-PG11	φ5~10
28	TS-PG11	φ5~10
	TS-PG13.5	φ6~12
	TS-PG16	φ10~14
32	TS-PG13.5	φ6~12
	TS-PG16	φ10~14
	TS-PG21	φ13~18
40	TS-PG16	φ10~14
	TS-PG21	φ13~18
	TS-PG29	φ18~25
48	TS-PG16	φ10~14
	TS-PG21	φ13~18
	TS-PG29	φ18~25
55	TS-PG29	φ18~25
	TS-PG36	φ22~32

Shell Size - Arrangement No.

View from mating face
Pin: J K: Socket

Table 1

: first mate/last break

● ϕ 1.5 \oplus ϕ 2.5 ϕ : mm

Spec.	YDK20					
Qty. of Contacts	2		3 (2+ \oplus)		4 (3+ \oplus)	
Contact Arrangement	Pin J2	K2 Socket	Pin J3	K3 Socket	Pin J4	K4 Socket
Contact Diameter×Qty.	ϕ 2.5 × 2		ϕ 2.5 × 2 + \oplus		ϕ 2.5 × 3 + \oplus	
Rated Current	\oplus 25A		\oplus 25A		\oplus 25A	
Rated Voltage	400V		400V		400V	
Rated Impulse Voltage	4000V		4000V		4000V	
Wire Gauge	<2.5mm ²		<2.5mm ²		<2.5mm ²	
Contact Resistance	<1m Ω		<1m Ω		<1m Ω	
Spec.	YDK20					
Qty. of Contacts	5 (4+ \oplus)		5a (4+ \oplus)		7 (6+ \oplus)	
Contact Arrangement	Pin J5	K5 Socket	Pin J5a	K5a Socket	Pin J7	K7 Socket
Contact Diameter×Qty.	ϕ 1.5 × 4 + \oplus		ϕ 1.5 × 2	ϕ 2.5 × 2 + \oplus	ϕ 1.5 × 6 + \oplus	
Rated Current	● 10A		● 10A	\oplus 25A	● 10A	
Rated Voltage	250V		250V	400V	250V	
Rated Impulse Voltage	2500V		2500V	4000V	2500V	
Wire Gauge	<1.5mm ²		<1.5mm ²	<2.5mm ²	<1.5mm ²	
Contact Resistance	<2.5m Ω		<2.5m Ω	<1m Ω	<2.5m Ω	
Spec.	YDK28					
Qty. of Contacts	4 (3+ \oplus)		7 (6+ \oplus)		10 (9+ \oplus)	
Contact Arrangement	Pin J4	K4 Socket	Pin J7	K7 Socket	Pin J10	K10 Socket
Contact Diameter×Qty.	ϕ 2.5 × 3 + \oplus		ϕ 2.5 × 6 + \oplus		ϕ 1.5 × 9 + \oplus	
Rated Current	\oplus 25A		\oplus 25A		● 10A	
Rated Voltage	400V		400V		250V	
Rated Impulse Voltage	4000V		4000V		2500V	
Wire Gauge	<2.5mm ²		<2.5mm ²		<1.5mm ²	
Contact Resistance	<1m Ω		<1m Ω		<2.5m Ω	

Shell Size - Arrangement No.

View from mating face

Pin: J K: Socket

Table 2

⊕ : first mate/last break

● φ 1.5 ⊕ φ 2.5 φ : mm

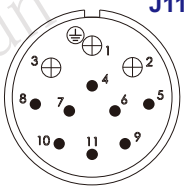
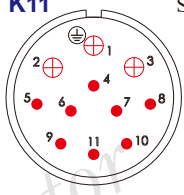
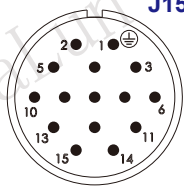
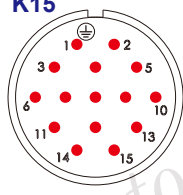
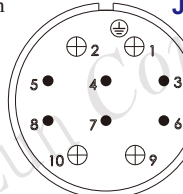
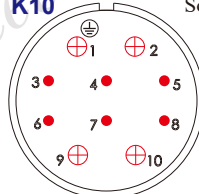
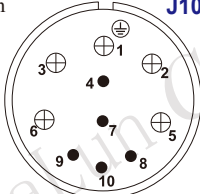
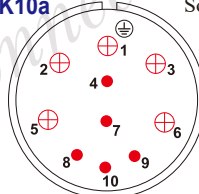
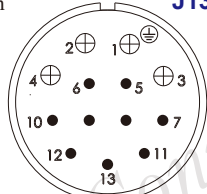
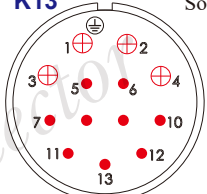
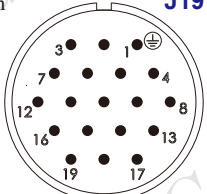
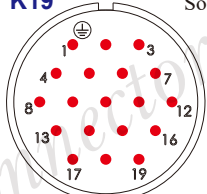
Spec.	YDK28			
Qty. of Contacts	11 (10+⊕)		15 (14+⊕)	
Contact Arrangement	Pin 	Socket 	Pin 	Socket 
Contact Diameter×Qty.	φ 1.5 × 8		φ 1.5 × 14 + ⊕	
Rated Current	● 10A		● 10A	
Rated Voltage	250V		250V	
Rated Impulse Voltage	2500V		2500V	
Wire Gauge	<1.5mm ²		<1.5mm ²	
Contact Resistance	<2.5mΩ		<2.5mΩ	
Spec.	YDK32			
Qty. of Contacts	10 (9+⊕)		10a (9+⊕)	
Contact Arrangement	Pin 	Socket 	Pin 	Socket 
Contact Diameter×Qty.	φ 1.5 × 6		φ 1.5 × 5	
Rated Current	● 10A		● 10A	
Rated Voltage	250V		400V	
Rated Impulse Voltage	2500V		4000V	
Wire Gauge	<1.5mm ²		<1.5mm ²	
Contact Resistance	<2.5mΩ		<2.5mΩ	
Spec.	YDK32			
Qty. of Contacts	13 (12+⊕)		19 (18+⊕)	
Contact Arrangement	Pin 	Socket 	Pin 	Socket 
Contact Diameter×Qty.	φ 1.5 × 9		φ 1.5 × 18 + ⊕	
Rated Current	● 10A		● 10A	
Rated Voltage	250V		250V	
Rated Impulse Voltage	2500V		2500V	
Wire Gauge	<1.5mm ²		<1.5mm ²	
Contact Resistance	<2.5mΩ		<2.5mΩ	

Shell Size - Arrangement No.

View from mating face
Pin: J K: Socket

Table 3

: first mate/last break

● ϕ 1.5 ϕ 2.5 ϕ : mm

Spec.	YDK40			
Qty. of Contacts	16 (15+)		22 (21+)	
Contact Arrangement	Pin 	Socket 	Pin 	Socket
Contact Diameter×Qty.	ϕ 2.5 × 15 +		ϕ 1.5 × 18	ϕ 2.5 × 3 +
Rated Current	25A		● 10A	25A
Rated Voltage	250V		250V	
Rated Impulse Voltage	2500V		2500V	
Wire Gauge	<2.5mm ²		<1.5mm ²	<2.5mm ²
Contact Resistance	<1m Ω		<2.5m Ω	<1m Ω
Spec.	YDK40			
Qty. of Contacts	24 (23+)		26 (25+)	
Contact Arrangement	Pin 	Socket 	Pin 	Socket
Contact Diameter×Qty.	ϕ 1.5 × 15	ϕ 2.5 × 8 +	ϕ 1.5 × 22	ϕ 2.5 × 3 +
Rated Current	● 10A	25A	● 10A	25A
Rated Voltage	250V		250V	
Rated Impulse Voltage	2500V		2500V	
Wire Gauge	<1.5mm ²	<2.5mm ²	<1.5mm ²	<2.5mm ²
Contact Resistance	<2.5m Ω	<1m Ω	<2.5m Ω	<1m Ω
Spec.	YDK40			
Qty. of Contacts	26a		31 (30+)	
Contact Arrangement	Pin 	Socket 	Pin 	Socket
Contact Diameter×Qty.	ϕ 1.5 × 15	ϕ 2.5 × 11	ϕ 1.5 × 30 +	
Rated Current	● 10A	25A	● 10A	
Rated Voltage	250V		250V	
Rated Impulse Voltage	2500V		2500V	
Wire Gauge	<1.5mm ²	<2.5mm ²	<1.5mm ²	
Contact Resistance	<2.5m Ω	<1m Ω	<2.5m Ω	

Shell Size - Arrangement No.

View from mating face

Pin: J K: Socket

● ϕ 1.5 ⊕ ϕ 2.5 ϕ : mm

Table 4

⊕ : first mate/last break

Spec.	YDK48							
Qty. of Contacts	26		27 (26 + ⊕)					
Contact Arrangement	Pin	J26	K26	Socket	Pin	J27	K27	Socket
Contact Diameter × Qty.	ϕ 2.5 × 26		ϕ 1.5 × 26		ϕ 2.5 (⊕)			
Rated Current	⊕ 25A				● 10A			
Rated Voltage	250V		250V		250V		250V	
Rated Impulse Voltage	2000V		2500V		2500V		2500V	
Wire Gauge	<2.5mm ²		<1.5mm ²		<1.5mm ²		<1.5mm ²	
Contact Resistance	<1m Ω		<2.5m Ω		<2.5m Ω		<2.5m Ω	
Spec.	YDK48							
Qty. of Contacts	38 (37 + ⊕)		42 (41 + ⊕)					
Contact Arrangement	Pin	J38	K38	Socket	Pin	J42	K42	Socket
Contact Diameter × Qty.	ϕ 1.5 × 33		ϕ 2.5 × 4 + ⊕		ϕ 1.5 × 41		ϕ 2.5 (⊕)	
Rated Current	● 10A		⊕ 25A		● 10A			
Rated Voltage	250V		250V		250V		250V	
Rated Impulse Voltage	2500V		2500V		2500V		2500V	
Wire Gauge	<1.5mm ²		<2.5mm ²		<1.5mm ²		<1.5mm ²	
Contact Resistance	<2.5m Ω		<1m Ω		<2.5m Ω		<2.5m Ω	
Spec.	YDK55							
Qty. of Contacts	53 (52 + ⊕)							
Contact Arrangement	Pin	J53		Socket				
Contact Diameter × Qty.	ϕ 1.5 × 48		ϕ 2.5 × 4 + ⊕					
Rated Current	● 10A		⊕ 25A					
Rated Voltage	250V		250V					
Rated Impulse Voltage	2500V		2500V					
Wire Gauge	<1.5mm ²		<2.5mm ²					
Contact Resistance	<2.5m Ω		<1m Ω					

Contact Part Number

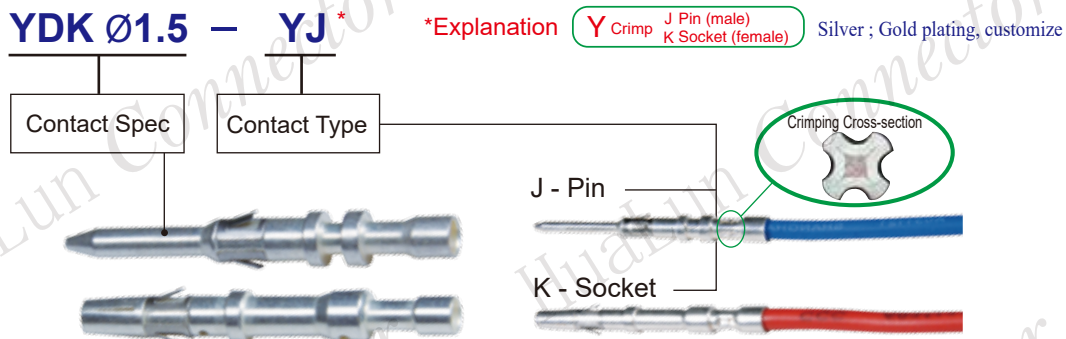

Example: YDKØ1.5-YJ Order pin, silver plating, Contact Spec is Ø1.5, wire barrel size is < 1.5mm²
 YDKØ2.5-YK Order socket, silver plating, Contact Spec is Ø2.5, wire barrel size is < 2.5mm²

Contact Spec	Code	Contact Adapter Wire		Connector retention within the insulated mounting plate	
		Conductor (metric) mm ²	Tensile strength N	Minimum axial load N	The maximum displacement of the connector mm
Ø1.5	YDKØ1.5-YJ	< 1.5	150	70	≤0.3
	YDKØ1.5-YK	< 1.5	150	70	≤0.3
Ø2.5	YDKØ2.5-YJ	< 2.5	230	90	≤0.3
	YDKØ2.5-YK	< 2.5	230	90	≤0.3

Tools

Hand Crimp Tool

Tool Order No.		M22520/1-01	D1612
Applicable Contact	Ø1.5	<p style="text-align: center;">Hand Crimp Tool</p>	<p style="text-align: center;">Locator</p>
	Ø2.5		

Figure (1)

Pneumatic Crimp Tool

Pneumatic crimp tool would be update efficiency and fit for mass crimping.

Please contact us for an order



Figure (2)

Extraction Tool

Tool Order No.	ET16	ET12
Applicable Contact	Ø1.5	Ø2.5



Figure (3)

Size of Receptacle

Receptacle ① (Panel Mounted) (No Protective Enclosure)

YDK CRIMP Panel Mounted Receptacle



Shell Spec	b	B	D0	D	L	N	G
20	24±0.2	32	20	26.5	34.5	12.5	3
28	30±0.2	40	28	33.5			
32	32±0.2	42	32	37.5			
40	40±0.2	50	40	45.5			
48	48±0.2	58	48	53.5			
55	52±0.2	64	55	60.5	35	13	

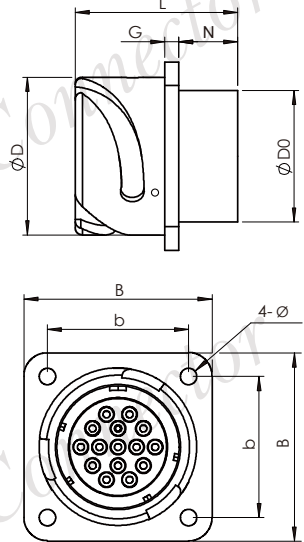

Receptacle Mounting & Mounting Hole

● Front Mounting

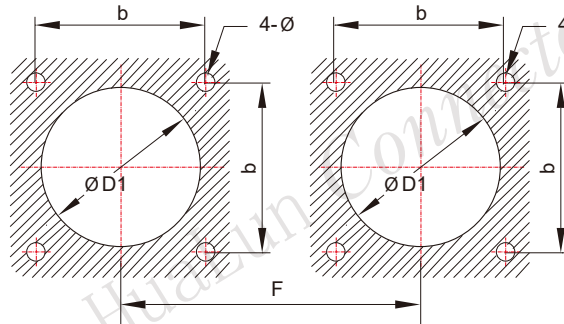
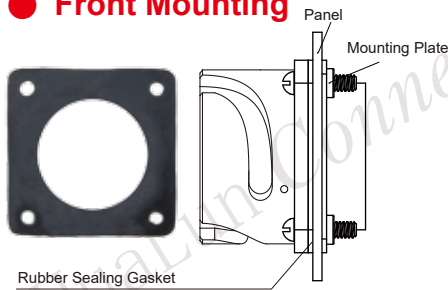

● Rear Mounting

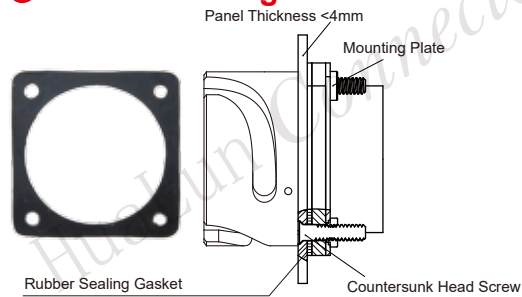

If it is rear-mounted, please specify when ordering, we provide rear-mounted rubber sealing gasket

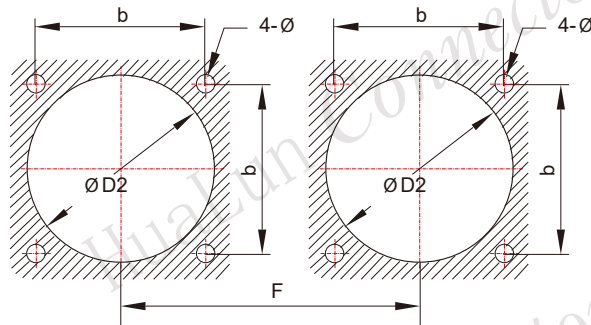

Mounting Hole Dimension

Unit: mm

Shell Spec	4-Ø	ØD1	ØD2	b	F
20	3.50	Ø21.00	Ø27.00	24±0.2	52.00
28		Ø28.50	Ø34.00	30±0.2	62.00
32		Ø32.50	Ø38.00	32±0.2	67.00
40		Ø41.00	Ø46.00	40±0.2	80.00
48	4.50	Ø49.00	Ø54.50	48±0.2	90.00
55		Ø56.00	Ø61.50	52±0.2	102.00

Size of Receptacle

Receptacle ② (Protective Enclosure) (Clamp/Gland)

● **ZP** - Straight, Protective Enclosure Receptacle

● **ZQ** - Straight, Protective Enclosure Receptacle

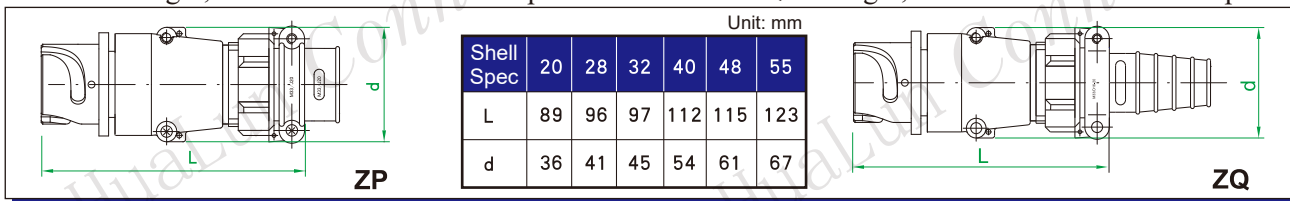

● **ZR** - (90° angled), Protective Enclosure Receptacle

● **ZS** - (90° angled), Protective Enclosure Receptacle

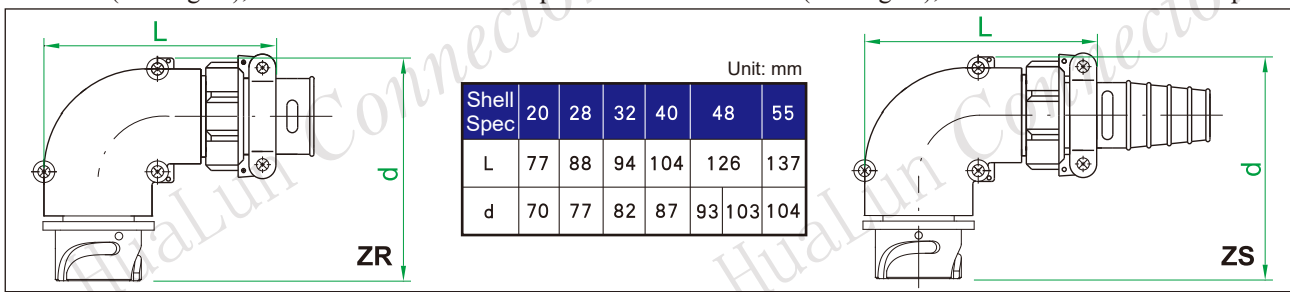

● **ZP-PG** Nylon hose gland

● **ZQ-PG** Cable gland

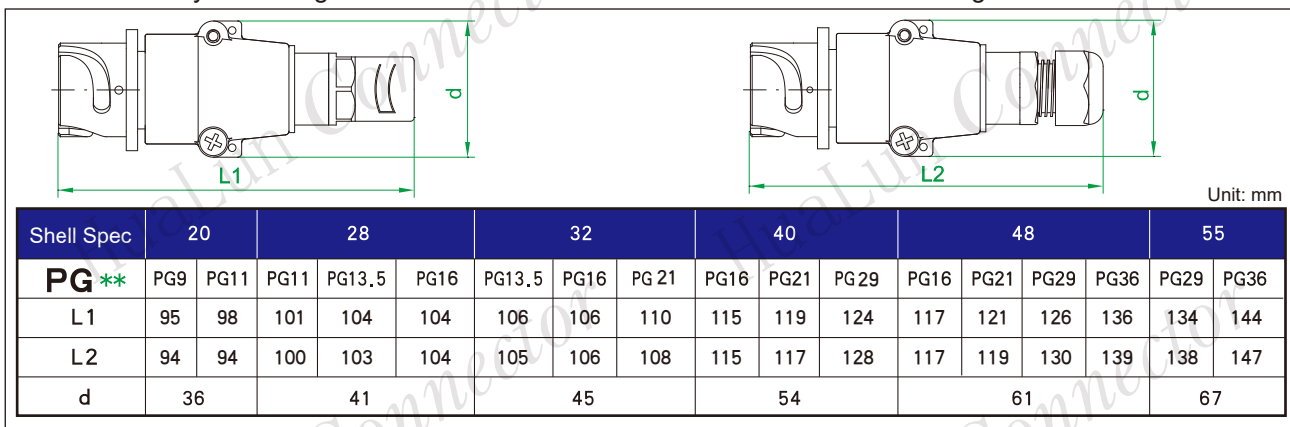

● **ZR-PG** Nylon hose gland

● **ZS-PG** Cable gland

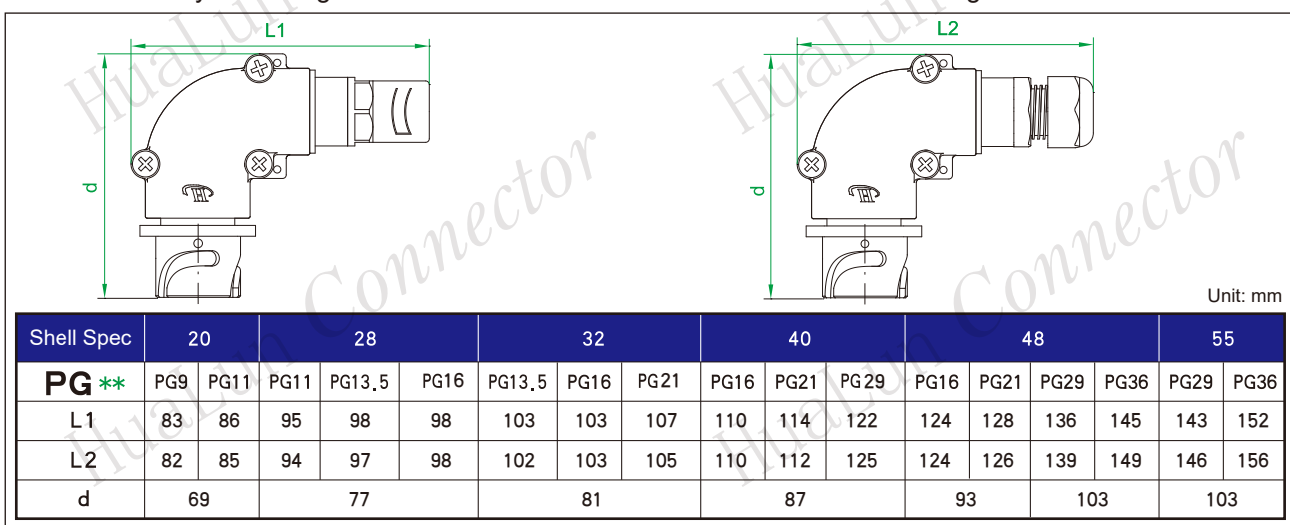

Size of Plug

Plug

● **TP** - Metal hose

● **TQ** - Cable clamp

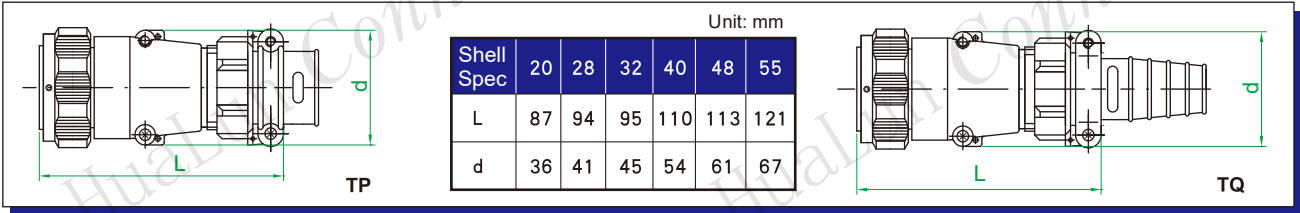

● **TR** - Metal hose

● **TS** - Cable clamp

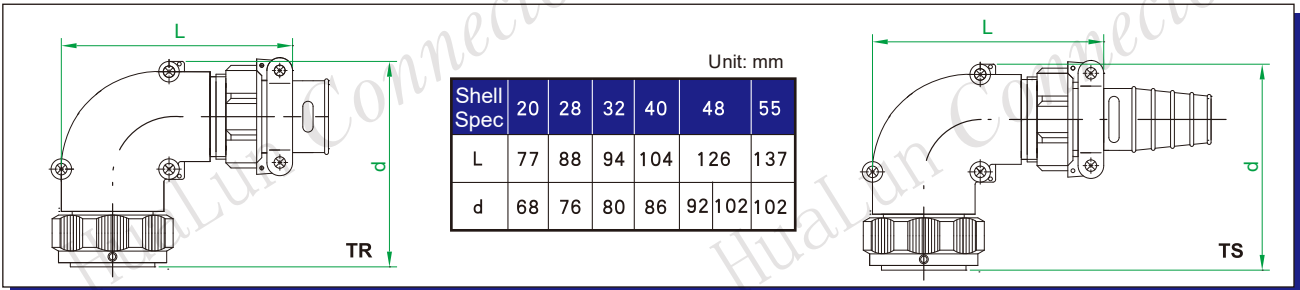

● **TP-PG** Nylon hose gland

● **TQ-PG** Cable gland

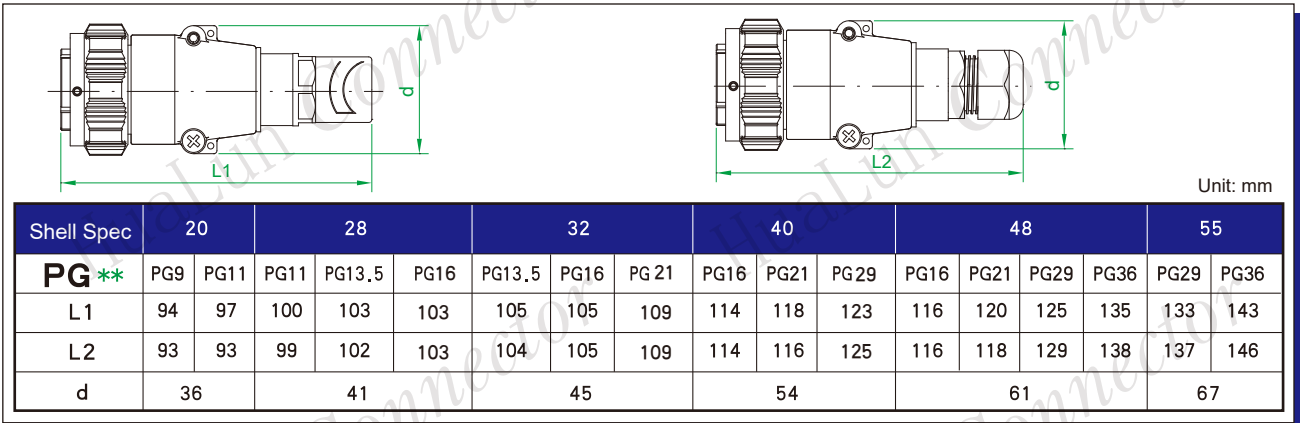

● **TR-PG** Nylon hose gland

● **TS-PG** Cable gland

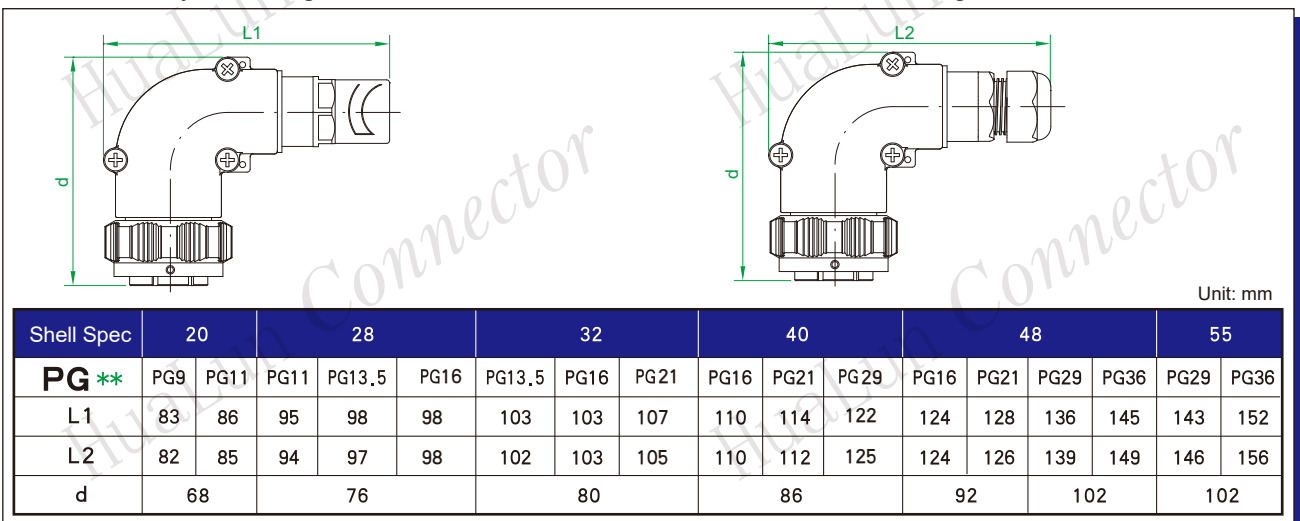

Accessories

1 Mounting Plate

Technical advantages: (1) Convenient and Fast
(2) Firm, Resistance to shock and vibration

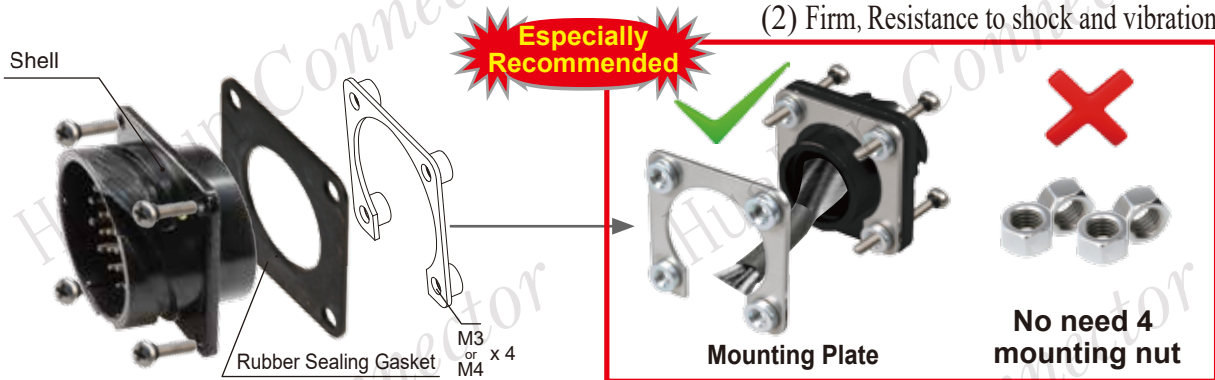

Mounting Plate Order Code, Size

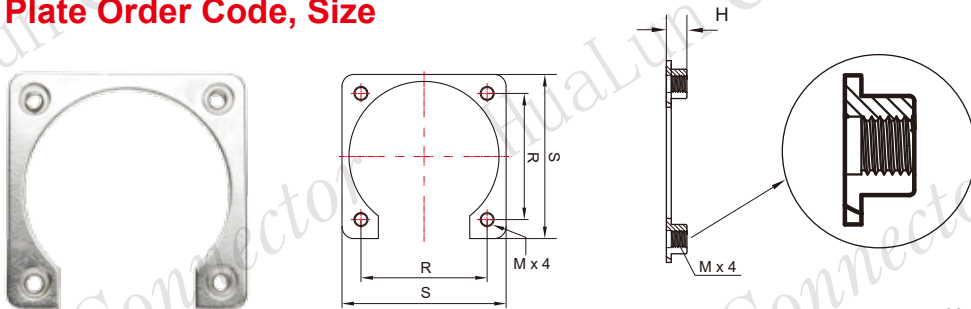

Unit: mm

Code	Shell Size	R	S	H	Thread M	Screw Spec
A20-K	20	24.00	30.00	2.60	M3	M3 x 10
A28	28	30.00	40.00			
A32	32	32.00	42.00			
A40	40	40.00	50.00	3.00	M4	M4 x 10
A48	48	48.00	58.00			
A55	55	52.00	64.00			

2 Plug Protection Cap



Dust Cap Code	Application
YDK20-TG	Shell 20 Plug
YDK28-TG	Shell 28 Plug
YDK32-TG	Shell 32 Plug
YDK40-TG	Shell 40 Plug
YDK48-TG	Shell 48 Plug
YDK55-TG	Shell 55 Plug

3 Receptacle Protection Cap



Dust Cap Code	Application
YDK20-ZG	Shell 20 Receptacle
YDK28-ZG	Shell 28 Receptacle
YDK32-ZG	Shell 32 Receptacle
YDK40-ZG	Shell 40 Receptacle
YDK48-ZG	Shell 48 Receptacle
YDK55-ZG	Shell 55 Receptacle



SHANGHAI HUALUN INSTRUMENTS & ELECTRONICS CO., LTD.

SALES & MARKETING DEPARTMENT

ADD: Rm3409, Tower2, Kerry Everbright City, West
Tianmu Rd218, Shanghai
P.C. : 200070
TEL : 86-21-63178300 ext. 205
FAX : 86-21-63178083
E-MAIL : liz@hualunconnector.com
WEB : www.hualunconnector.com

FACTORY & HEADQUARTERS

ADD: Factory building 1 & 3, Jinjiang Industrial
Park, Qianyang Rd271, Shanghai
P.C. : 200333

- Hualun reserves the right to modify the technical and upgrade of the product
- Any form of diversion of this cataloge must be authorized by Hualun